

TP4-WT4
Four input load cell monitor
Operation and instruction manual

AMALGAMATED INSTRUMENT CO

*Unit 5, 28 Leighton Place Hornsby
NSW 2077 Australia*

*Telephone: +61 2 9476 2244
Facsimile: +61 2 9476 2902*

ABN: 80 619 963 692

*e-mail: sales@aicpl.com.au
Internet: www.aicpl.com.au*

Table of Contents

1	Introduction	3
2	Mechanical Installation	6
3	Electrical Installation	9
4	Function tables - summary of setup functions	13
5	Explanation of functions	20
6	Specifications	53
7	Guarantee and service	55

1 Introduction



This manual contains information for the installation and operation of the TP4-WT4 Load Cell Monitor. The instrument has a full scale range of 0.5mV/V to 100mV/V. Excitation voltages of 5 Volt or 10 Volt are selectable by PCB links. The TP4 has a 6 digit, 20mm LED display which is readable to a distance of 10 metres. The TP4 housing is an IP65 rated enclosure.



The TP4 has four individual 4 wire mV/V output load cell/pressure sensor channel inputs and is suitable for linear measurement of weight, pressure, force, torque and similar variables. Calibration, setpoint and other set up functions are easily achieved by push buttons located on the front panel.

Isolated analog retransmission (4-20mA) and non isolated RS232 serial communications is provided as standard (configurable as ASCII or Modbus RTU). Isolated RS485 serial communication is optionally available and ordered will be fitted instead of the RS232 communications. A separate addendum to this manual deals with the serial output commands including Modbus RTU and optional data logger functions.

Four standard inbuilt relays provide alarm/on-off control functions.

The instrument may be used in two basic modes namely:

Arithmetic mode - the default display (**CH0**) shows the arithmetic sum of all the active channels i.e. if all four channels are selected then the result is channel 1 plus channel 2 plus channel 3 plus channel 4. The  and  buttons can also be used to manually toggle between channels.

Scanning mode - the instrument will scan all active channels but not sum the channels. The rate at which the scanned channels values are rotated on display can be set by the user. The  and  buttons can also be used to manually toggle between channels.

Unless otherwise specified at the time of order, your TP4-WT4 has been factory set to a standard configuration. The configuration and calibration is easily changed by the user. Initial changes may require dismantling the instrument to alter PCB links, other changes are made by push button functions.



Full electrical isolation between power supply, input and analog retransmission output (RS232 is not isolated) is provided by the TP4 thereby eliminating grounding and common voltage problems. This isolation feature makes the TP4 ideal for interfacing to PLCs and other data acquisition devices. TP4 Monitors are designed for high reliability in industrial applications.

The high brightness LED display provides good visibility, even in areas with high ambient light levels. A feature of the TP4-WT4 is the programmable display brightness function, this allows the unit to be operated with low display brightness to improve readability in darker areas.

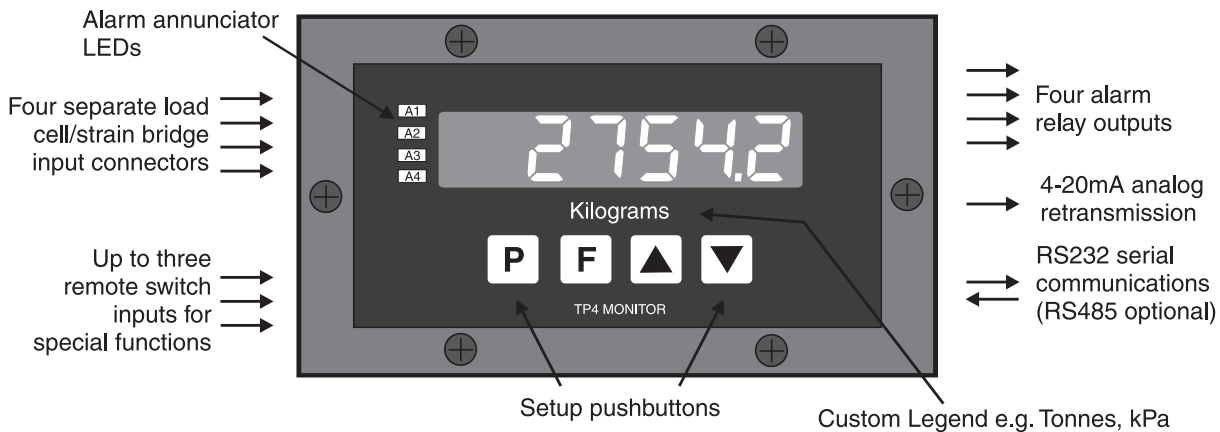

TP4-WT4 inputs and outputs



1.1 Viewing individual channels

The front panel  or  button can be used to view each input individually. The channel number will be displayed prior to the reading from each input e.g. **CH2** will be displayed immediately before the channel 2 reading. In arithmetic (**ARITH**) mode **CHO** is the total display i.e. the arithmetic sum of all active channels. In scan (**SCAN**) mode each channel display can be set to automatically rotate. In addition to viewing individual channels the alarm relays and analog retransmission can be programmed to operate from the total (in arithmetic mode) or from individual channels. Each channel can be interrogated individually or collectively via **POLL** mode if serial communication is used.

1.2 Input percentage values

In addition to viewing each channel the  and  buttons can be used to display the “input percentage” for each channel. These messages will only be seen whilst the instrument is powered up in **CAL** mode or if the **ACCES** function is set to **ALL**. These percentages are preceded by the message **, n 1**, **, n 2**, **, n 3** or **, n 4** indicating which channel is being viewed. This display shows the input as a percentage of the full scale of the analog to digital mV/V input range (selected at the **RANGE** function). The overrange error message “- - - -” will be seen at a nominal value of 20% above the selected mV/V input. For example if 5mV/V is selected (**RANGE** function set to **5.0**) and 10V excitation is used then the analog to digital converter will expect to receive from 0 to 50mV at full load and will give an overrange message at approx. 60mV and above. For this input type, a channel with a 30mV input will give a 50% reading i.e. **50.00**. These input percentage figures are useful in multi load cell systems since they show a “live” input reading which is not affected by calibration scaling. By comparing the values for each the user is able to see how the load is being distributed between the systems load cells. For example in a 4 load cell platform readings of **, n 1 50.00**, **, n 2 48.00**, **, n 3 48.00**, **, n 4 26.00** would indicate that, whilst load cells on inputs 1, 2, and 3 have roughly equal loads on them, input 4 is experiencing just over half of the load of the other cells.

1.3 Calibration methods

Each input must be individually scaled or calibrated. Two methods are available, only one of these methods should be used. The calibration procedure is explained more fully in this manual but the basic methods are:

1. Live input calibration. This method requires that different loads are placed on the sensor and a live input calibration is used to enter the values to be displayed for each load. For example in calibrating channel 1 using 2 points the functions **CH1CAL1** and **CH1CAL2** are used to scale the display. If linearisation is required the to four calibration points per channel can be selected.
2. Scaling by entering the sensor mV/V and capacity values. If live input calibration is not possible the the mV/V output and full capacity of the sensor can be entered. Once these values are entered the input must be placed at zero load condition and one of the methods of zeroing the display must be used. For example to scale channel 1 using this method use the **CH1ECAL** function.

Note: this second method can only be used if the number of calibration points selected is two.

2 Mechanical Installation

The instrument is designed to be wall mounted using the four mounting brackets provided. Carefully measure and drill four holes as shown below. An optional panel mount kit is available for use with the TP4 see section 2.2. Overall enclosure dimensions are 255mm x 145mm x 125mm(max.).

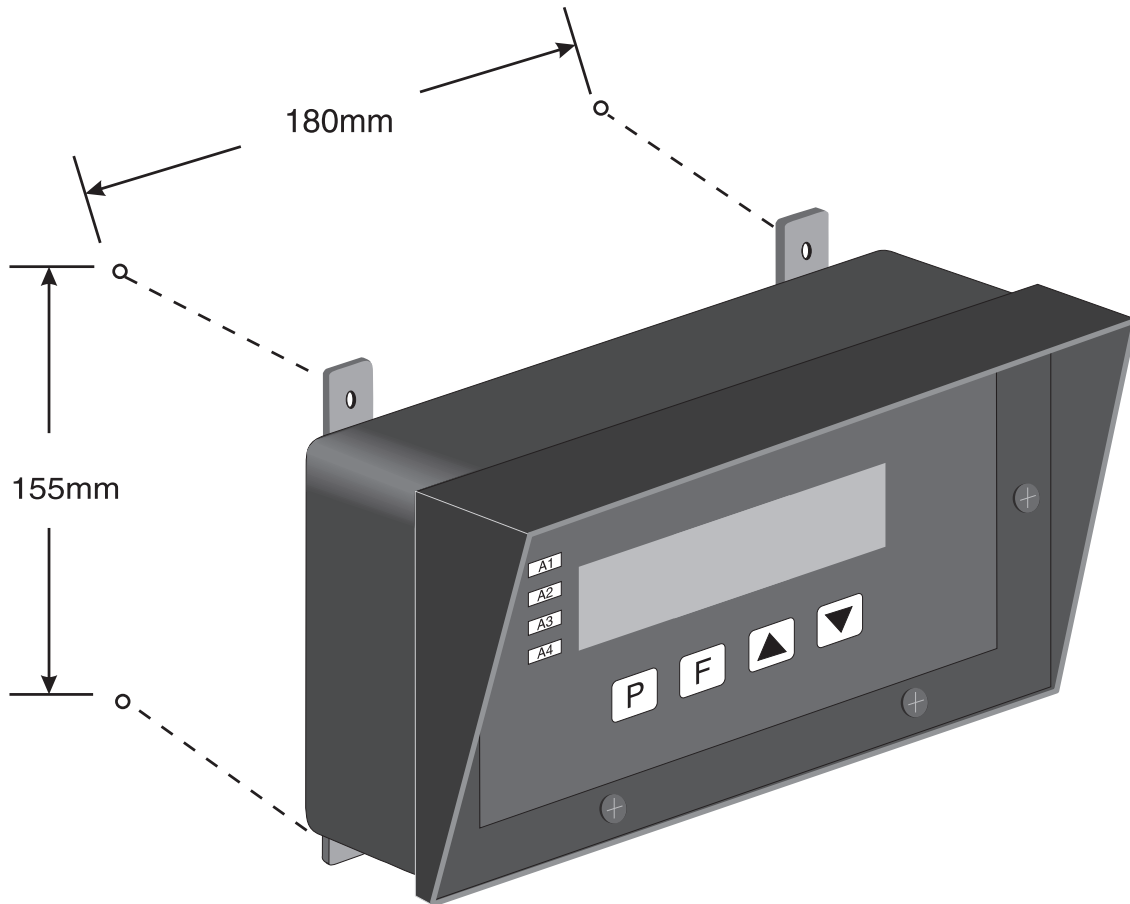

Mounting Hole Locations

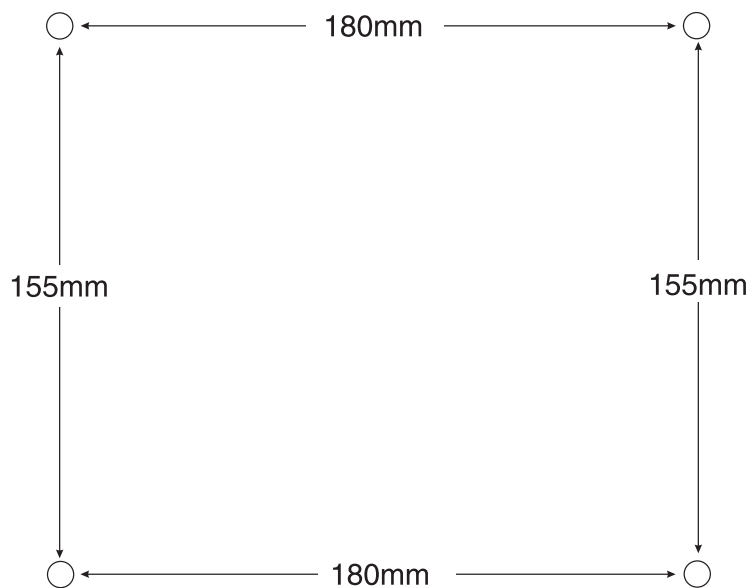

2.1 Fitting cable glands

The instrument is supplied with one PG9 gland.

The weatherproof enclosure has incorporated mounting pillars for securing boards, plates etc. on the base and immediately under the front panel. The case material is Black ASA. Cable glands are readily obtainable from electrical wholesalers and some hardware shops if required. Circuit boards should be removed prior to drilling. The hood is moulded to the case but cases without the hood are optionally available.

Suggested hole locations for up to 3 cable glands.

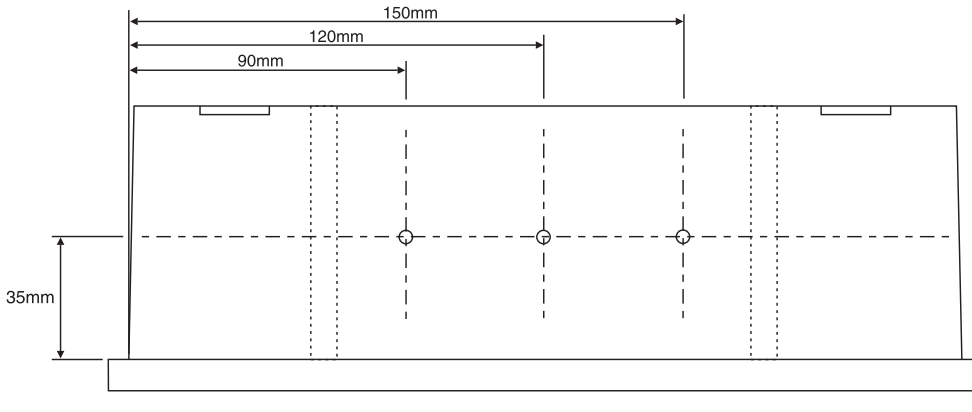

Suggested hole placement selection.

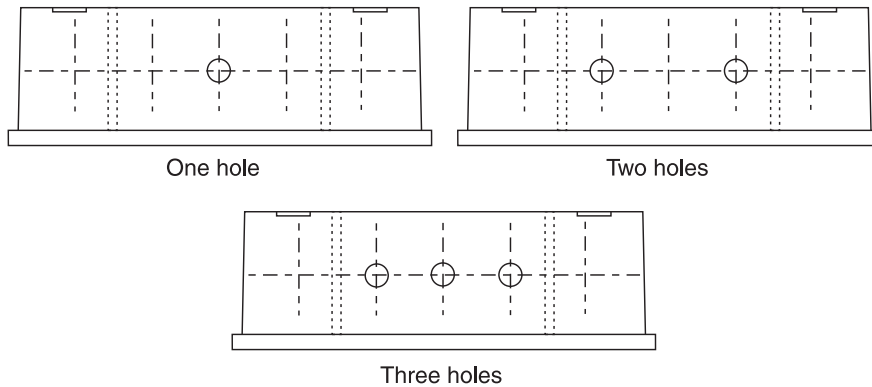

Suggested hole locations for up to 2 cable glands with side entry

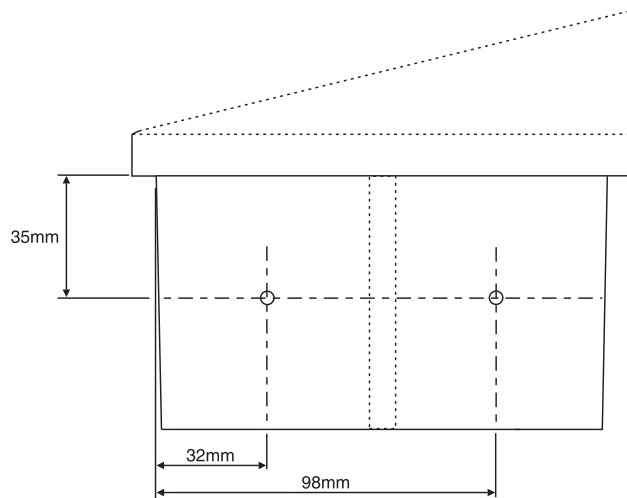

2.2 Panel mounting

An optional panel mount kit is available. The kit comprises two adjustable bolts and two brackets. A case without the moulded hood is optionally available and is often used when panel mounting displays since it provides a mounting which projects less far the surface.

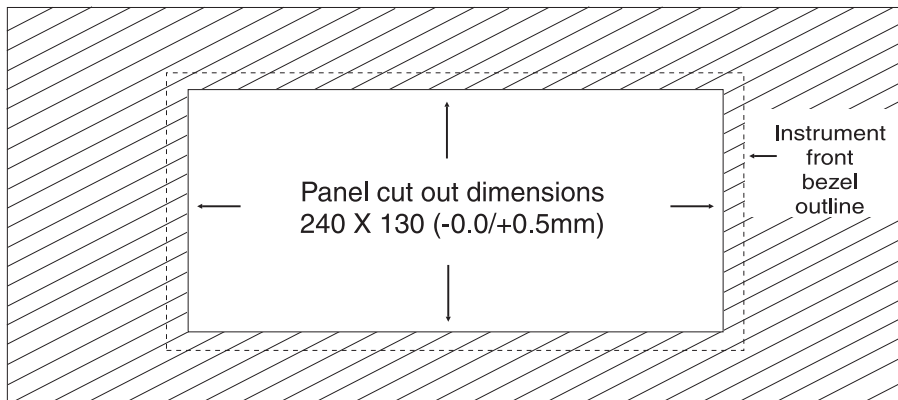
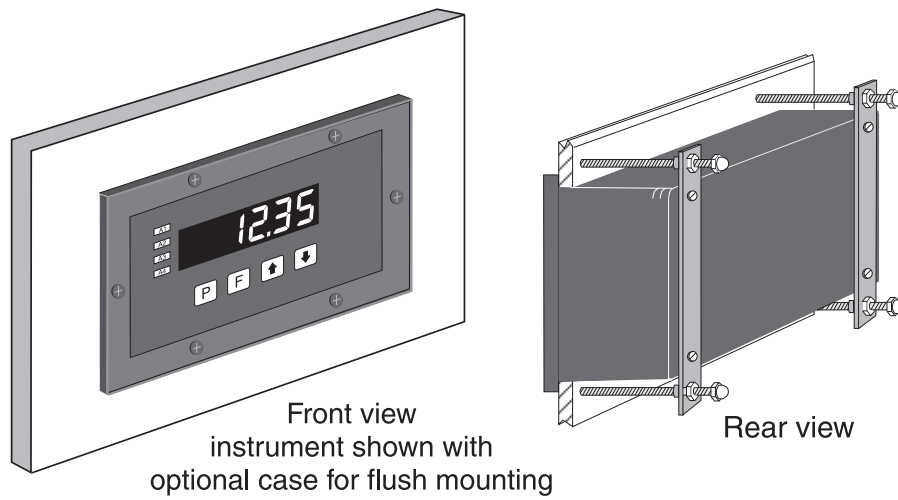

3 Electrical Installation

The instrument is designed for continuous operation and no power switch is fitted to the unit. It is recommended that an external switch and fuse be provided to allow the unit to be removed for servicing.

Plug in terminal blocks are provided to make installation easier. The terminal blocks allow for wires of up to 1.5mm² (2.5mm² for power supply and relay terminal blocks) to be fitted. Connect the wires to the appropriate terminals as indicated in the appropriate diagrams in this chapter. When power is applied the instrument will cycle through a display sequence indicating the software version and other status information.

When an input is applied a display indication should be seen. The instrument will be set to a factory default scaling (unless otherwise arranged) and so it may be necessary to scale the instrument to the required engineering units for your application. See Chapter 5 for a description of the calibration/scaling functions.

Input board layout

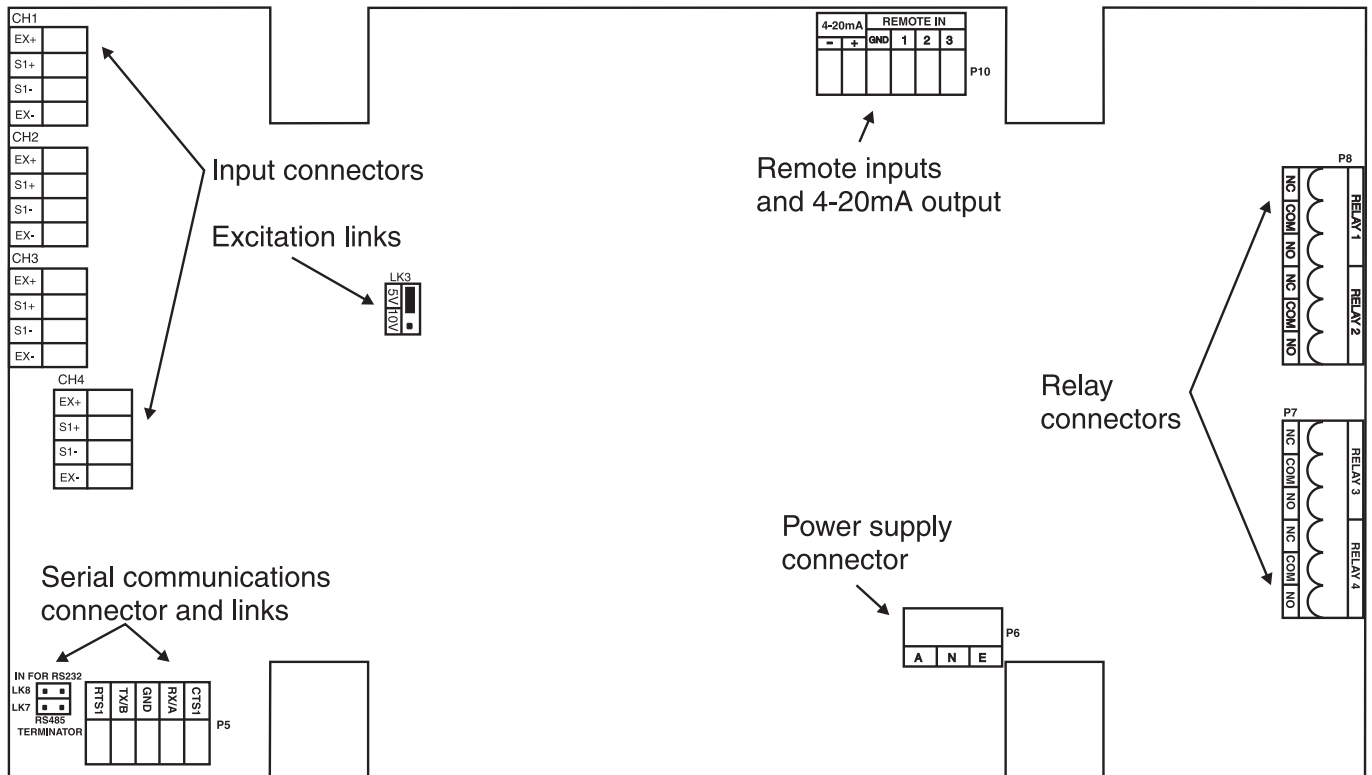

3.1 Power supply connections

The power supply for the instrument is factory fitted and is of a fixed type. If you are unsure of the supply requirement for your instrument it can be determined by the model number on the instrument label:-

- TP4-WT4-240-..... Requires 240VAC
- TP4-WT4-110-..... Requires 110VAC
- TP4-WT4-DC-..... Requires 12 to 48VDC
- TP4-WT4-ACD-..... Requires 12 to 48VAC

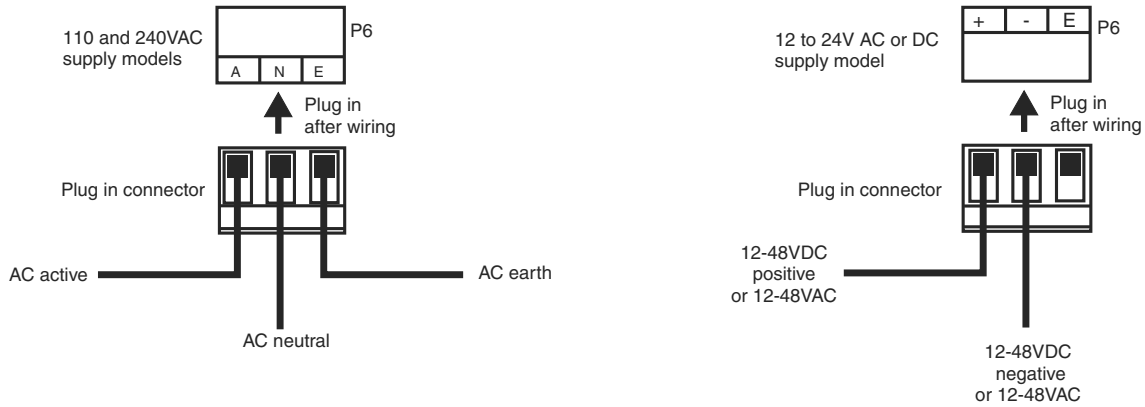

3.2 Load cell connections

The TP4-WT4 will accept 4 wire load cell/pressure sensors. Excitation voltages of 5V or 10V are provided and are link selectable (LK3). The use of shielded cable is recommended to help reduce electrical noise pickup. Connection of multiple parallel cells to each input: With 10V excitation the minimum load on each input is 160Ω nominal. With 5V excitation the minimum load on each input is 80Ω nominal (e.g. four 350Ω load cells in parallel).

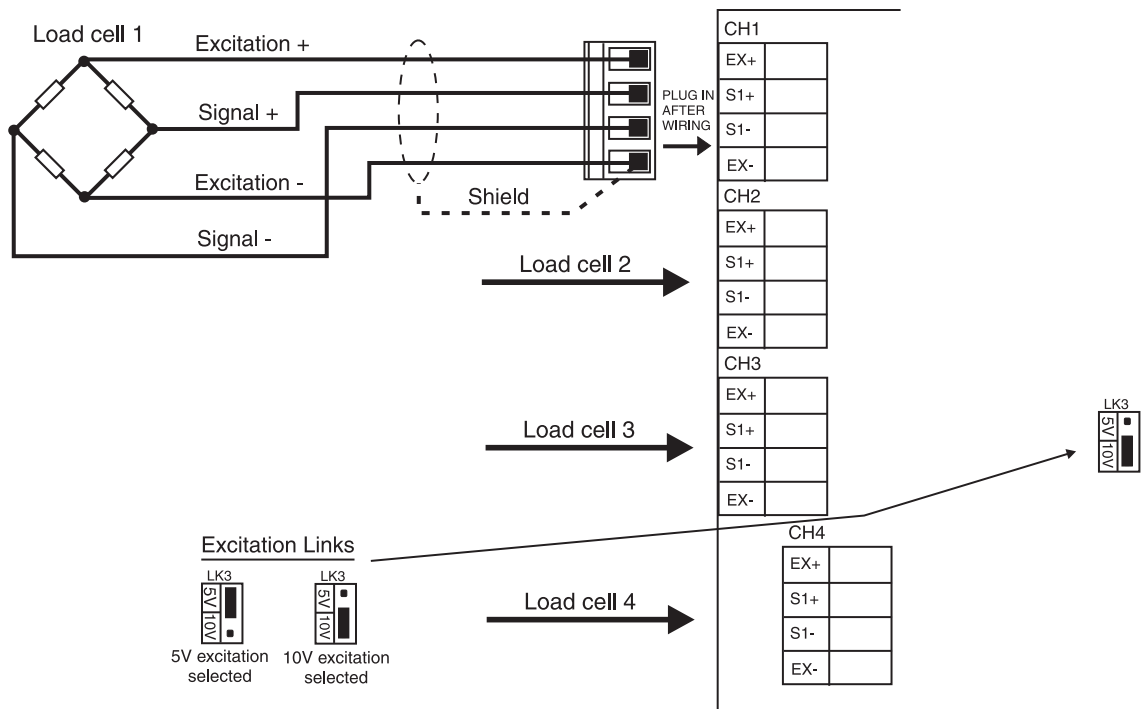

3.3 Relay connections

The TP4 is supplied with 4 alarm relays as standard. The relays are all single pole, double throw types and are rated at 5A, 240VAC into a resistive load. The relay contacts are voltage free. When switching inductive loads (e.g. a solenoid) a suppressor circuit should be used across the load or across the relay contacts.

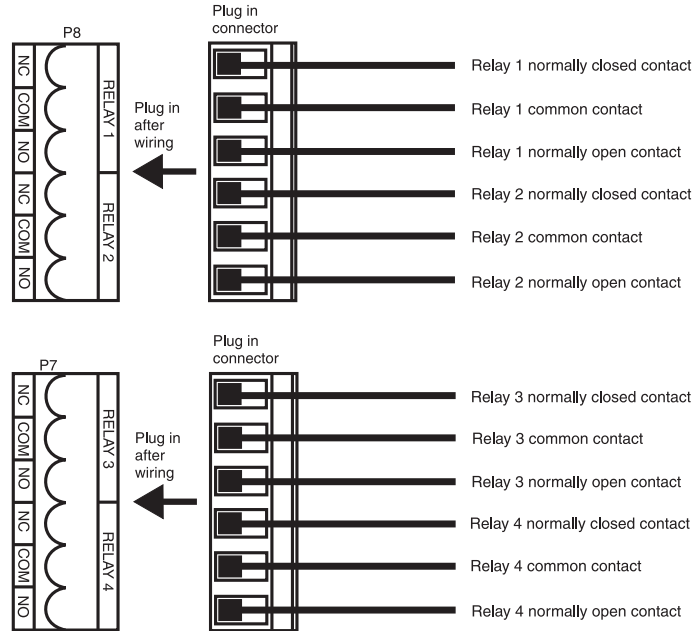

3.4 Remote input and analog retransmission

A remote input is provided to allow special function operation (see Chapter 5 for a description of the remote input functions **F.I.N.P.**). A separate remote input switch connection is required for operation of the chosen function. Choose a momentary switch for those functions requiring a brief closure (e.g. tare and zero) or latching switch for functions which require a longer closure (e.g. peak hold and display hold). The 4-20mA output is connected as shown. The 4-20mA output is powered by the TP4 and will drive the 4-20mA signal into loads of up to 800Ω.

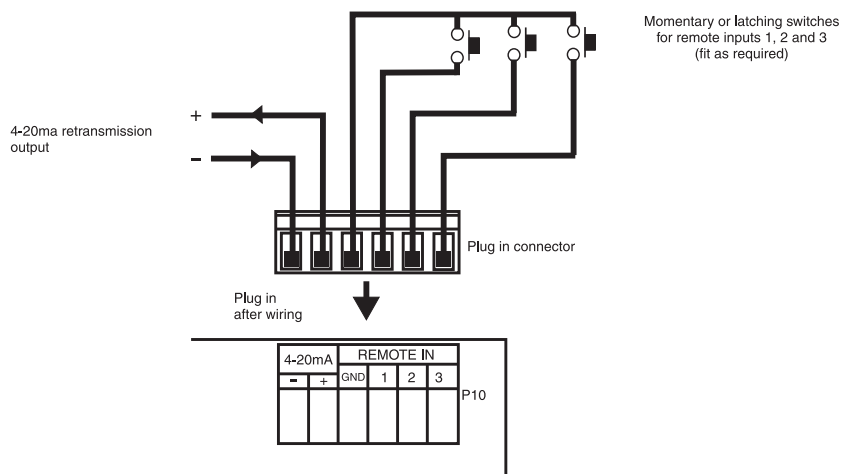

3.5 Serial communications connections

When using the standard RS232 output link LK8 must be in, Tx at the TP4 end connects to Rx at the other end of the serial link, likewise Rx at the TP4 end connects to Tx at the other end of the link. When using the optional RS485 connections are A the TP4 end to A at the other end of the link and B at the TP4 end to B at the other end. The ground line should be connected in each case. If the TP4 is the first or last unit in a RS485 chain then the link LK7 may need to be in, this places a terminating resistor across the input to help prevent signal reflections in long cable runs.

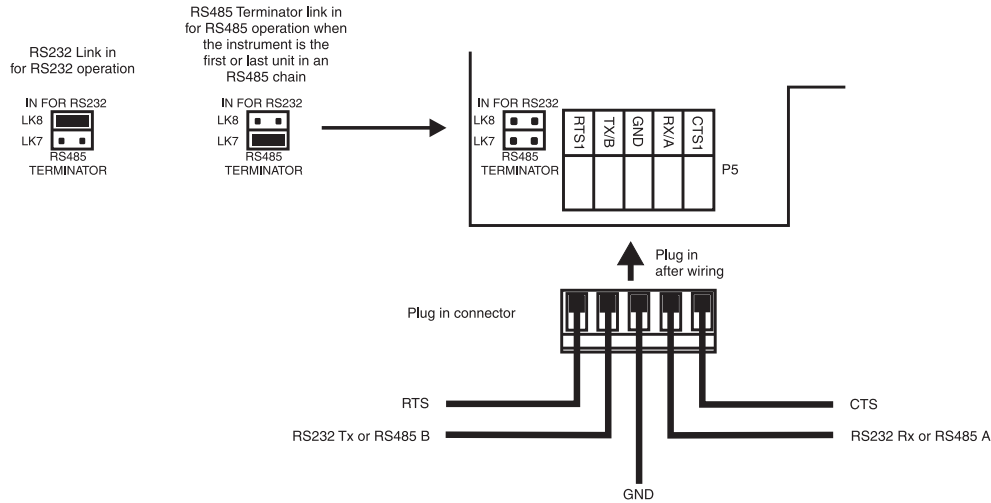

Standard PC 9 pin male "D" type RS232 serial port connector.
Rear terminals (solder side) shown.

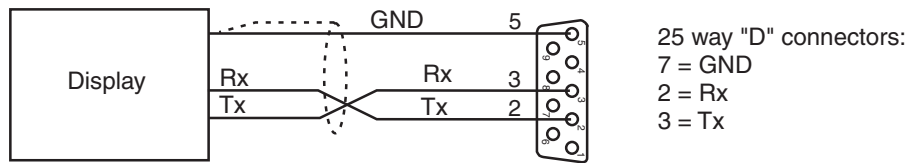

RS485 connection terminals may vary, check documentation when connecting.
Terminal A is sometimes labeled "+" and terminal B is sometimes labeled "-"

A separate addendum to this manual deals with the serial output functions.

4 Function tables - summary of setup functions

Note: the order in which the functions appear on the display may not be exactly as shown below. The availability and order of functions is determined by choice of function settings and options fitted.

Functions in this first table are available in **FUNC** or **CAL** mode

Display	Function	Range	Default	Your record	Ref/Page
RxLo	Low setpoint value for designated alarm relay <i>x</i>	Any display value or OFF	OFF	See 4.1	5.1 / 22
RxHi	High setpoint value for designated alarm relay <i>x</i>	Any display value or OFF	OFF	See 4.1	5.2 / 22
RxHY	Hysteresis value for the designated alarm relay <i>x</i> .	0 to 9999	10	See 4.1	5.3 / 23
Rxtt	Trip time delay for the designated alarm relay <i>x</i> .	0.0 to 999.9	0.0	See 4.1	5.4 / 24
Rxrt	Reset time delay for the designated alarm relay <i>x</i> .	0.0 to 999.9	0.0	See 4.1	5.5 / 24
Rxn.o or Rxn.c	Alarm relay <i>x</i> action to normally open or normally closed	Rxn.o or Rxn.c	Rxn.o	See 4.1	5.6 / 24
RxSP or Rxt I etc.	Relay operation independent setpoint or trailing setpoint	RxSP or Rxt I etc.	RxSP	See 4.1	5.7 / 25
Rx FREE	Alarm relay “free fall” or “in flight” value	Any display value	0	See 4.1	5.8 / 25
Rx FREE	Alarm relay “free fall” or “in flight” value	Any display value	0	See 4.1	5.9 / 26
Rx FREE	Alarm relay “free fall” or “in flight” value	Any display value	0	See 4.1	5.10 / 26
Rx FREE	Alarm relay “free fall” or “in flight” value	Any display value	0	See 4.1	5.11 / 26
br9t	Display brightness level	1 to 15	15		5.12 / 26
SLUE br9t	Display brightness level for slave display	1 to 63	63		5.13 / 26
dULL	Display remote brightness switching	0 to 15	1		5.14 / 27

(*Optional)—this function will only be accessible if the relevant option is fitted

Functions in this second table are available only in **CAL** mode or if **ACCS** is set to **ALL**

Display	Function	Range	Default	Your record	Ref/Page
FEC-	Analog output option low display value	Any display value	0		5.15 / 27
FEC+	Analog output option high display value	Any display value	1000		5.16 / 27
drnd	Display rounding	1 to 5000	1		5.17 / 28
dCPt	Decimal point for arithmetic operation	0 to 0.00005 etc.	0		5.18 / 28
Ch 1 dCPt	Decimal point for channel 1	0, 0.1 etc.	0		5.19 / 28
Ch 2 dCPt	Decimal point for channel 2	0, 0.1 etc.	0		5.20 / 28
Ch 3 dCPt	Decimal point for channel 3	0, 0.1 etc.	0		5.21 / 29
Ch 4 dCPt	Decimal point for channel 4	0, 0.1 etc.	0		5.22 / 29
FLtr	Digital filter	0 to 8	2		5.23 / 29
PRnt SECS	Printer output time period	1 to 7200	1		5.24 / 29
SEt OPEr	Set operation mode	Arth or SCAN	Arth		5.25 / 30
SCAN PERd	Scan period	0 to 240 seconds	0		5.26 / 30
SCAN CHLS	Number of channels to scan	1 to 4	4		5.27 / 30
FRtE	Sample rate in samples/sec.	5, 10, 15, 20, 30, 40 or 50	10		5.28 / 31
FR9.1	mV/V input range for channel 1	0.5, 1.0, 2.5, 5.0, 10, 25, 50 or 100	2.5		5.29 / 31
FR9.2	mV/V input range for channel 2	0.5, 1.0, 2.5, 5.0, 10, 25, 50 or 100	2.5		5.30 / 31
FR9.3	mV/V input range for channel 3	0.5, 1.0, 2.5, 5.0, 10, 25, 50 or 100	2.5		5.31 / 31
FR9.4	mV/V input range for channel 4	0.5, 1.0, 2.5, 5.0, 10, 25, 50 or 100	2.5		5.32 / 32

(*Optional)—this function will only be accessible if the relevant option is fitted

F.I NP	Remote input (external input) one function	NONE . P.HLd . d.HLd.H. . Lo.H. Lo . tARF .ZEFO . SP.Ac . No.Ac . I.CAL .btch or dull	NONE		5.33 / 32
F.I N2	Remote input (external input) two function	Same as F.I NP	NONE		5.34 / 33
F.I N3	Remote input (external input) three function	Same as F.I NP	NONE		5.35 / 33
Pbut	P button function (for instruments with front P button)	NONE.H. . Lo.H. Lo . tARF .ZEFO or btch	NONE		5.36 / 34
ACCS	Access mode	OFF .EASY . NONE or ALL	OFF		5.37 / 34
SPAC	Setpoint access mode	A 1.A 1-2 . A 1-3 or A 1-4	A 1		5.38 / 34
L. n PtS. 1	Lineariser points for channel 1, allows up to 4 calibration points	2.3 or 4	2		5.39 / 35
L. n PtS.2	Lineariser points for channel 2, allows up to 4 calibration points	2.3 or 4	2		5.40 / 35
L. n PtS.3	Lineariser points for channel 3, allows up to 4 calibration points	2.3 or 4	2		5.41 / 35
L. n PtS.4	Lineariser points for channel 4, allows up to 4 calibration points	2.3 or 4	2		5.42 / 35
CH 1 CAL 1	Channel 1 first calibration point	n/a	n/a		5.43 / 36
CH 1 CAL2	Channel 1 second calibration point	n/a	n/a		5.44 / 37
CH 1 CAL3	Channel 1 third live calibration point	Any display value	n/a		5.45 / 38
CH 1 CAL4	Channel 1 fourth live calibration point	Any display value	n/a		5.46 / 38
CH2 CAL 1	Channel 2 first calibration point	n/a	n/a		5.47 / 38
CH2 CAL2	Channel 2 second calibration point	n/a	n/a		5.48 / 38
CH2 CAL3	Channel 2 third live calibration point	Any display value	n/a		5.49 / 38

(*Optional)—this function will only be accessible if the relevant option is fitted

CH2 CAL4	Channel 2 fourth live calibration point	Any display value	n/a		5.50 / 39
CH3 CAL1	Channel 3 first calibration point	n/a	n/a		5.51 / 39
CH3 CAL2	Channel 3 second calibration point	n/a	n/a		5.52 / 39
CH3 CAL3	Channel 3 third live calibration point	Any display value	n/a		5.53 / 39
CH3 CAL4	Channel 3 fourth live calibration point	Any display value	n/a		5.54 / 39
CH4 CAL1	Channel 4 first calibration point	n/a	n/a		5.55 / 40
CH4 CAL2	Channel 4 second calibration point	n/a	n/a		5.56 / 40
CH4 CAL3	Channel 4 third live calibration point	Any display value	n/a		5.57 / 40
CH4 CAL4	Channel 4 fourth live calibration point	Any display value	n/a		5.58 / 40
CH1 ECAL	Channel one mV/V input scaling	-32.000 to 32.000	n/a		5.59 / 40
CH2 ECAL	Channel two mV/V input scaling	-32.000 to 32.000	n/a		5.60 / 41
CH3 ECAL	Channel three mV/V input scaling	-32.000 to 32.000	n/a		5.61 / 41
CH4 ECAL	Channel four mV/V input scaling	-32.000 to 32.000	n/a		5.62 / 42
CH1 ZERO	Channel 1 set zero	n/a	n/a		5.63 / 42
CH2 ZERO	Channel 2 set zero	n/a	n/a		5.64 / 42
CH3 ZERO	Channel 3 set zero	n/a	n/a		5.65 / 42
CH4 ZERO	Channel 4 set zero	n/a	n/a		5.66 / 43
CH1 OFFSET	Channel 1 calibration offset	Any display value	n/a		5.67 / 43
CH2 OFFSET	Channel 2 calibration offset	Any display value	n/a		5.68 / 43
CH3 OFFSET	Channel 3 calibration offset	Any display value	n/a		5.69 / 43
CH4 OFFSET	Channel 4 calibration offset	Any display value	n/a		5.70 / 44

(*Optional)—this function will only be accessible if the relevant option is fitted

CH1 2.rn9	Channel 1 zero range	- 1999 to 9999 or OFF	1000		5.71 / 44
CAL 2.Ch1	Channel 1 zero reference	Any display value	n/a		5.72 / 44
CH2 2.rn9	Channel 2 zero range	- 1999 to 9999 or OFF	1000		5.73 / 45
CAL 2.Ch2	Channel 2 zero reference	Any display value	n/a		5.74 / 45
CH3 2.rn9	Channel 3 zero range	- 1999 to 9999 or OFF	1000		5.75 / 45
CAL 2.Ch3	Channel 3 zero reference	Any display value	n/a		5.76 / 45
CH4 2.rn9	Channel 4 zero range	- 1999 to 9999 or OFF	1000		5.77 / 45
CAL 2.Ch4	Channel 4 zero reference	Any display value	n/a		5.78 / 46
A1	Alarm relay 1 operation mode	LI UE, Ch1 Ch2, Ch3, Ch4, tAFE, btch, bch2, P.HLd, d.HLd, Hi, Lo or di SP	LI UE		5.79 / 46
A2	Alarm relay 2 operation mode	LI UE, Ch1 Ch2, Ch3, Ch4, tAFE, btch, bch2, P.HLd, d.HLd, Hi, Lo or di SP	LI UE		5.80 / 48
A3	Alarm relay 3 operation mode	LI UE, Ch1 Ch2, Ch3, Ch4, tAFE, btch, bch2, P.HLd, d.HLd, Hi, Lo or di SP	LI UE		5.81 / 48
A4	Alarm relay 4 operation mode	LI UE, Ch1 Ch2, Ch3, Ch4, tAFE, btch, bch2, P.HLd, d.HLd, Hi, Lo or di SP	LI UE		5.82 / 48

(*Optional)—this function will only be accessible if the relevant option is fitted

FEC	Analog output operation mode	L1 UE, CH1 CH2, CH3, CH4, tAFE, btch, bch2, P.HLd, d.HLd, H1, Lo or d1 SP	L1 UE		5.83 / 48
Log UPdt	Data logger logging period (*Optional)	0.10 to 60.00	1.00		5.84 / 48
Clr Log	Clear data logger memory (*Optional)	0.10 to 60.00	n/a		5.85 / 49
SEt rtc	Set datalogger clock (*Optional)	0.01 to 24.00	n/a		5.86 / 49
SEt dAtE	Set datalogger date (*Optional)	01.01 to 31.12	Date		5.87 / 49
SEt YEAr	Set datalogger year (*Optional)	1970 to 2037	Year		5.88 / 50
bAUd	Baud rate for serial communications	300.600. 1200.2400. 4800.9600. 19.2 or 38.4	9600		5.89 / 50
Prty	Parity for serial communications	NONE.EVEN or odd	NONE		5.90 / 50
Q.PUt	Output for serial communications	d1 SP.Cont. POLL. A.buS. n.buS. t.PrE. C.ALL. NONE.dSP.4 or dSP.6	Cont		5.91 / 50
Addr	Instrument address for serial communications	0 to 31	0		5.92 / 51

(*Optional)—this function will only be accessible if the relevant option is fitted

4.1 Settings for relays - record settings here

Display	Relay 1	Relay 2	Relay 3	Relay 4
<i>Rxn.o</i> or <i>Rxn.c</i>				
	n/a			
<i>Rx FREE</i>				
<i>R1</i>		n/a	n/a	n/a
<i>R2</i>	n/a		n/a	n/a
<i>R3</i>	n/a	n/a		n/a
<i>R4</i>	n/a	n/a	n/a	

5 Explanation of functions

The setup and calibration functions are configured through a push button sequence. The push buttons located at the front of the instrument are used to alter settings. Two basic access modes are available:

FUNC mode (simple push button sequence) allows access to commonly set up functions such as alarm setpoints.

CAL mode (power up sequence plus push button sequence) allows access to all functions including calibration parameters.

Once **CAL** or **FUNC** mode has been entered you can step through the functions, by pressing and releasing the **F** push button, until the required function is reached. Changes to functions are made by pressing the **▲** or **▼** push button (in some cases both simultaneously) when the required function is reached. See the flow chart example on the following page.

Entering **CAL** Mode



1. Remove power from the instrument. Hold in the **F** button and reapply power. The display will briefly indicate **CAL** as part of the "wake up messages" when the **CAL** message is seen you can release the button. Move to step 2 below.



2. When the "wake up" messages have finished and the display has settled down to its normal reading press, then release the **F** button. Move to step 3 below.



3. Within 2 seconds of releasing the **F** button press, then release the **▲** and **▼** buttons together. The display will now indicate **FUNC** followed by the first function.

Note: If step 1 above has been completed then the instrument will remain in this **CAL** mode state until power is removed. i.e. there is no need to repeat step 1 when accessing function unless power has been removed.

Entering **FUNC** Mode

No special power up procedure is required to enter **FUNC** mode.



1. When the "wake up" messages have finished and the display has settled down to its normal reading press, then release the **F** button.



2. Within 2 seconds of releasing the **F** button press, then release the **▲** and **▼** buttons together. The display will now indicate **FUNC** followed by the first function.

Example: Entering **FUNC** mode to change alarm 1 high function **AIH**, from **OFF** to **100**

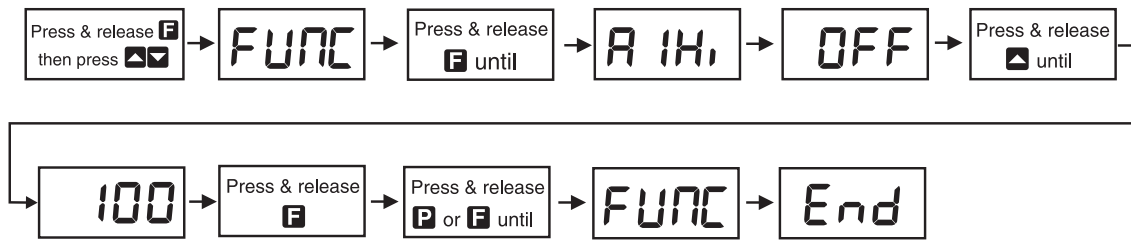

Example: Entering **CAL** mode to change decimal point **CH1 dCPT** function from **0** to **0.02**

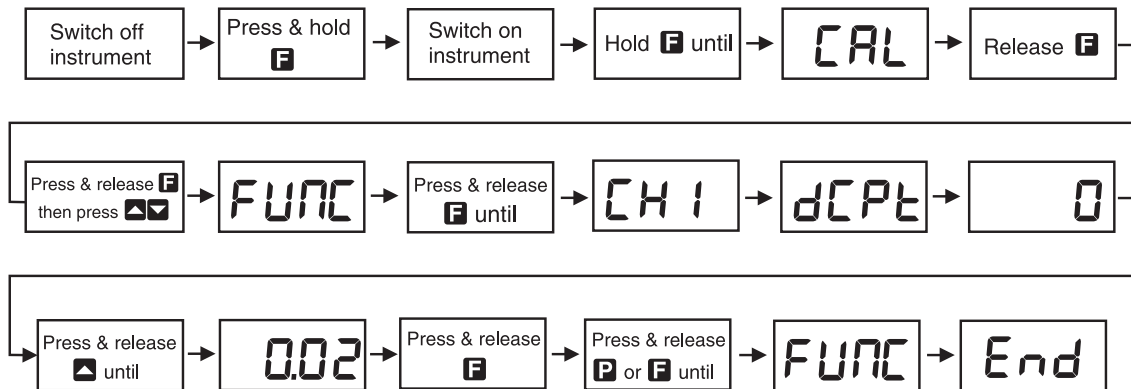

Easy alarm relay adjustment access facility

The display has an easy alarm access facility which allows access to the alarm setpoints simply by pressing the **F** button. The first setpoint will then appear and changes to this setpoint may be made to this setpoint via the **▲** or **▼** buttons. Press the **F** button to accept any changes or to move on to the next setpoint. The instrument must be set in the manner described below to allow the easy access facility to work:

1. A remote input function such as **RI NP** function must be set to **SPAC** or the **ACCS** function must be set to **EASY**.
2. At least one alarm must have a setpoint, nothing will happen if all the alarm setpoints are set to **OFF**.
3. The **SPAC** function must be set to allow access to the relays required e.g. if set to **A 1-2** then the easy access will work only with alarm relays 1 and 2.
4. The instrument must be in normal measure mode i.e. if the instrument is powered up so that it is in **CAL** mode then the easy access will not function. If in doubt remove power from the instrument, wait for a few seconds then apply power again.
5. If the easy access facility is used then the only way to view or alter any other function settings is to power up via **CAL** mode i.e. there is no entry to **FUNC** mode functions unless the instrument is powered up in **CAL** mode.

Explanation of Functions

5.1 Alarm relay low setpoint

Display: $RxLo$
Range: Any display value or **OFF**
Default Value: **OFF**

Displays and sets the low setpoint value for the designated alarm relay x . Note x will be replaced by the relay number when displayed e.g. $R1Lo$ for relay 1. Use this low setpoint function if a relay operation is required when the display value becomes equal to or less than the low setpoint value. To set a low alarm value go to the $RxLo$ function and use the \blacktriangle or \blacktriangledown push buttons to set the value required then press **F** to accept this value. The low alarm setpoint may be disabled by pressing the \blacktriangle and \blacktriangledown push buttons simultaneously. When the alarm is disabled the display will indicate **OFF**. If the relay is allocated both a low and high setpoint then the relay will activate when the value displayed moves outside the band set by the low and high setpoints. The value at which the relay will reset is controlled by the $RxHy$ function.

Example:

If $R1Lo$ is set to **10** then relay 1 will activate when the display value is 10 or less.

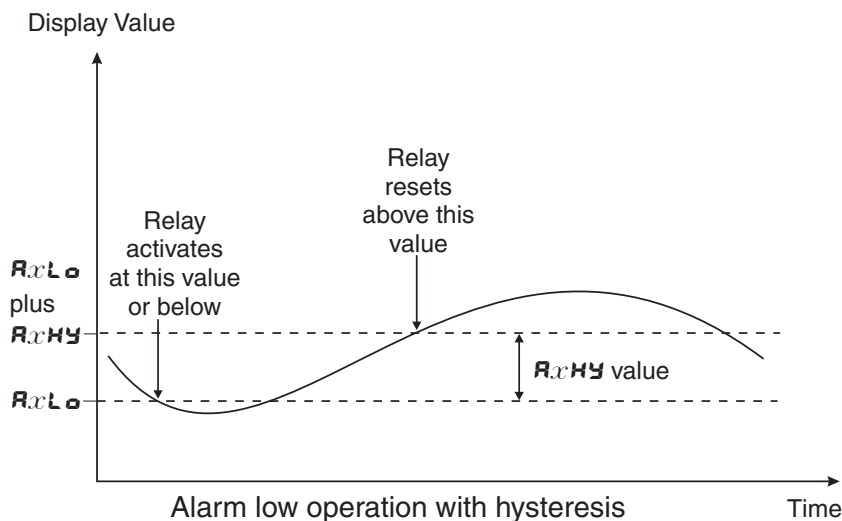

5.2 Alarm relay high setpoint

Display: RxH
Range: Any display value or **OFF**
Default Value: **OFF**

Displays and sets the high setpoint value for the designated alarm relay x . Note x will be replaced by the relay number when displayed e.g. $R1H$ for relay 1. Use this high setpoint function if a relay operation is required when the display value becomes equal to or more than the low setpoint value. To set a high alarm value go to the RxH function and use the \blacktriangle or \blacktriangledown push buttons to set the value required then press **F** to accept this value. The high alarm setpoint may be disabled by pressing the \blacktriangle and \blacktriangledown push buttons simultaneously. When the alarm is disabled the display will indicate **OFF**. If the relay is allocated both a low and high setpoint then the relay will activate when the value displayed moves outside the band set by the low and high setpoints. The value at which the relay will reset is controlled by the $RxHy$ function.

Example:

If **A 1H** is set to **100** then relay 1 will activate when the display value is **100** or higher.

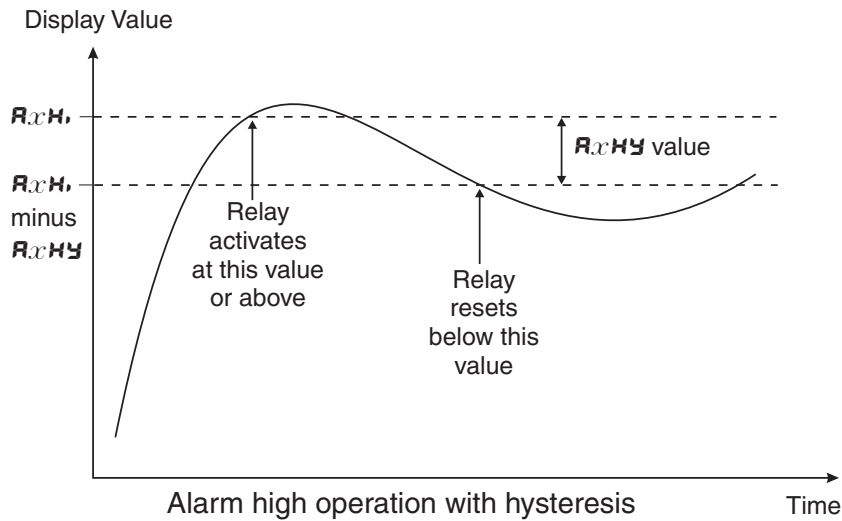

5.3 Alarm relay hysteresis (deadband)

- Display: **AxHY**
- Range: **0** to **9999**
- Default Value: **10**

Displays and sets the alarm relay hysteresis limit for the designated relay *x*. Note *x* will be replaced by the relay number when displayed e.g. **A 1HY** for relay 1. To set a relay hysteresis value go to the **AxHY** function and use the **▲** or **▼** push buttons to set the value required then press **F** to accept this value. The hysteresis value is common to both high and low setpoint values. The hysteresis value may be used to prevent too frequent operation of the relay when the measured value is rising and falling around setpoint value. e.g. if **A 1HY** is set to zero the alarm will activate when the display value reaches the alarm setpoint (for high alarm) and will reset when the display value falls below the setpoint, this can result in repeated on/off switching of the relay at around the setpoint value.

The hysteresis setting operates as follows: In the high alarm mode, once the alarm is activated the input must fall below the setpoint value minus the hysteresis value to reset the alarm. e.g. if **A 1H** is set to **50.0** and **A 1HY** is set to **3.0** then the setpoint output relay will activate once the display value goes to **50.0** or above and will reset when the display value goes below **47.0** i.e. at **46.9** or below. In the low alarm mode, once the alarm is activated the input must rise above the setpoint value plus the hysteresis value to reset the alarm. e.g. if **A 1Lo** is to **20.0** and **A 1HY** is set to **10.0** then the alarm output relay will activate when the display value falls to **20.0** or below and will reset when the display value goes above **30.0** i.e. at **30.1** or above. The hysteresis units are expressed in displayed engineering units.

Example: If **A 1H** is set to **100** and **A 1HY** is set to **10** then relay 1 will activate when the display value is **100** or higher and will reset at a display value of **89** or lower.

5.4 Alarm relay trip time

Display: ***Ax.t.t***
Range: **0.0 to 999.9**
Default Value: **0.0**

Displays and sets the alarm trip time in seconds and tenths of seconds. The trip time is common for both alarm high and low setpoint values. The trip time provides a time delay before the alarm relay will activate when an alarm condition is present. The alarm condition must be present continuously for the whole trip time period before the alarm will activate. If the input moves out of alarm condition during this period the timer will reset and the full time delay will be restored. This trip time delay is useful for preventing an alarm trip due to short non critical deviations from setpoint. The trip time is selectable over **0.0 to 999.9** seconds. To set a trip time value go to the ***Ax.t.t*** function and use the **▲** or **▼** push buttons to set the value required then press **F** to accept this value.

Example: If ***A 1.t.t*** is set to **5.0** seconds then the display must indicate an alarm value for a full 5 seconds before relay 1 will activate.

5.5 Alarm relay reset time

Display: ***Ax.r.t***
Range: **0.0 to 999.9**
Default Value: **0.0**

Displays and sets the alarm reset delay time in seconds and tenths of seconds. The reset time is common for both alarm high and low setpoint values. With the alarm condition is removed the alarm relay will stay in its alarm condition for the time selected as the reset time. If the input moves back into alarm condition during this period the timer will reset and the full time delay will be restored. The reset time is selectable over **0.0 to 999.9** seconds. To set a reset time value go to the ***Ax.r.t*** function and use the **▲** or **▼** push buttons to set the value required then press **F** to accept this value.

Example: If ***A 1.r.t*** is set to **10.0** seconds then the resetting of alarm relay 1 will be delayed by 10 seconds.

5.6 Alarm relay normally open/closed

Display: ***Ax.n.o*** or ***Ax.n.c***
Range: ***Ax.n.o*** or ***Ax.n.c***
Default Value: ***Ax.n.o***

Displays and sets the setpoint alarm relay *x* action to normally open (de-energised) or normally closed (energised), when no alarm condition is present. Since the relay will always be open open circuit between the NO and COM terminals when power is removed a normally closed alarm is often used to provide a power failure alarm indication. To set the alarm for normally open or closed go to the ***Ax.n.o*** or ***Ax.n.c*** function and use the **▲** or **▼** push buttons to set the required operation then press **F** to accept this selection.

Example:

If set to ***A 1.n.o*** alarm relay 1 will be open circuit between the NO and COM terminals when the

display is outside alarm condition and will be closed (short circuit across NO and COM terminals) when the display is in alarm condition. The NC and COM terminals will be in the opposite state.

5.7 Alarm relay setpoint or trailing operation

Display: $RxSP$ or $RxL1$ etc.

Range: $RxSP$ or $RxL1$ etc.

Default Value: $RxSP$

Relay operation independent setpoint or trailing setpoint, this function will not be seen unless extra optional relays are fitted. Each alarm, except relay 1, may be programmed to operate with an independent setpoint value or may be linked to operate at a fixed difference to another relay setpoint, known as trailing operation. The operation is as follows:

Alarm 1 (**R1**) is always independent. Alarm 2 (**R2**) may be independent or may be linked to Alarm 1. Alarm 3 (**R3**) may be independent or may be linked to Alarm 1 or Alarm 2. Alarm 4 (**R4**) may be independent or may be linked to Alarm 1, Alarm 2 or Alarm 3. The operation of each alarm is selectable by selecting, for example, (Alarm 4) **R4.SP** = Alarm 4 normal setpoint or **R4.L1** = Alarm 4 trailing Alarm 1 or **R4.L2** = Alarm 4 trailing Alarm 2 or **R4.L3** = Alarm 4 trailing Alarm 3. For trailing set points the setpoint value is entered as the difference from the setpoint being trailed. If the trailing setpoint is to operate ahead of the prime setpoint then the value is entered as a positive number and if operating behind the prime setpoint then the value is entered as a negative number. **Example:**

With Alarm 2 set to trail alarm 1, if **R1H** is set to **1000** and **R2H** is set to **50** then Alarm 1 will activate at **1000** and alarm 2 will activate at **1050** (i.e. 1000 + 50). If Alarm 2 had been set at **-50** then alarm 2 would activate at **950** (i.e. 1000 - 50).

5.8 Alarm relay 1 free fall

Display: $RxFREE$

Range: Any display value

Default Value: **0**

Free fall alarm value - the alarm free fall value is used to provide an offset to the alarm operation. This value can be set anywhere within the measuring range of the instrument and will operate in engineering units e.g. kilograms, tonnes etc. In most applications this function will be used to force the alarm to operate at a given measured quantity prior to the actual alarm relay target weight setting. **Example:**

In a filling application the target weight is 40.0 kg but it is found that due to “in flight” or “free fall” of product the target is consistently 0.5kg over weight. If **R1H** is set to **40.0** and **R1FREE** is set to **0.5** then relay 1 will activate when the display value reaches **39.5**. With 0.5kg of “free fall” this should ensure that the target weight of 40.0kg is reached.

5.9 Alarm relay 2 free fall

Display: **Rx F F E E**
Range: Any display value
Default Value: **0**

Sets the free fall value for alarm relay 2. See **R ! F F E E** function for further description.

5.10 Alarm relay 3 free fall

Display: **Rx F F E E**
Range: Any display value
Default Value: **0**

Sets the free fall value for alarm relay 3. See **R ! F F E E** function for further description.

5.11 Alarm relay 4 free fall

Display: **Rx F F E E**
Range: Any display value
Default Value: **0**

Sets the free fall value for alarm relay 4. See **R ! F F E E** function for further description.

5.12 Display brightness

Display: **br 9t**
Range: **1** to **15**
Default Value: **15**

Displays and sets the digital display brightness. The display brightness is selectable from **1** to **15**, where **1** = lowest intensity and **15** = highest intensity. This function is useful for improving the display readability in dark areas or to reduce the power consumption of the instrument. See also the **dull** function. To set brightness level go to the **br 9t** function and use the **▲** or **▼** push buttons to set the value required then press **F** to accept this value.

5.13 Display brightness for slave display

Display: **SLUE br 9t**
Range: **1** to **63**
Default Value: **63**

Displays and sets the digital display brightness of the slave display when the TP4-WT4 is connected to the slave display model LD-SL via RS485 serial communications. The display brightness is selectable from **1** to **63**, where **1** = lowest intensity and **63** = highest intensity. The slave display has no function settings and therefore the display brightness needs to be set via the sending unit.

5.14 Display remote brightness switching

Display: **dull**
Range: **0** to **15**
Default Value: **1**

Displays and sets the level for remote input brightness switching, see **FN** function. When a remote input is set to **dull** the remote input can be used to switch between the display brightness level set by the **bright** function 5.12 and the display brightness set by the **dull** function. The display dull level is selectable from **0** to **15**, where **0** = lowest intensity and **15** = highest intensity. This function is useful in reducing glare when the display needs to be viewed in both light and dark ambient light levels. To set dull level go to the **dull** function and use the **▲** or **▼** push buttons to set the value required then press **F** to accept this value.

Example: With **dull** set to **4** and **bright** set to **15** and the **FN** function set to **dull** the display brightness will change from the **15** level to **4** when a switch connected to the remote input terminals is activated.

5.15 Analog output option low value

Display: **FEC-**
Range: Any display value
Default Value: **0**

Displays and sets the 4–20mA analog retransmission output low value (4mA) in displayed units. To set the analog output low value go to the **FEC-** function and use the **▲** or **▼** push buttons to set the required value then press **F** to accept this selection.

Example:

If it is required to retransmit 4mA when the display indicates **0.0** then select **0.0** in this function using the **▲** or **▼** button.

5.16 Analog output option high value

Display: **FEC+**
Range: Any display value
Default Value: **1000**

Displays and sets the 4–20mA analog retransmission output high value (20mA) in displayed units. To set the analog output high value go to the **FEC+** function and use the **▲** or **▼** push buttons to set the required value then press **F** to accept this selection.

Example:

If it is required to retransmit 20mA when the display indicates **14.0** then select **14.0** in this function using the **▲** or **▼** button.

5.17 Display rounding

Display: **drnd**
Range: **1** to **5000**
Default Value: **1**

Displays and sets the display rounding value. This value may be set to 1 - 5000 displayed units. Display rounding is useful for reducing the instrument resolution without loss of accuracy in applications where it is undesirable to display to a fine tolerance. To set the display rounding value go to the **drnd** function and use the **▲** or **▼** push buttons to set the required value then press **F** to accept this selection.

Example: If set to **10** the display values will change in multiples of 10 only i.e. display moves from **10** to **20** to **30** etc.

5.18 Decimal point for arithmetic sum

Display: **dCPE**
Range: **0** to **0.00005** etc.
Default Value: **0**

Displays and sets the decimal point for the arithmetic sum and all input channels, this function only applies when the **SEt OPEr** function is set to **Arth**. By pressing the **▲** or **▼** pushbutton at the **dCPE** function the decimal point position may be set. The display will indicate as follows: **0** (no decimal point), **0.1** (1 decimal place), **0.02** (2 decimal places) etc. up to 5 decimal places. Note if the decimal point is altered the display will need to be recalibrated and alarm etc. settings checked.

5.19 Decimal point for channel 1

Display: **Ch 1dCPE**
Range: **0, 0.1** etc.
Default Value: **0**

Displays and sets the individual decimal point setting for input channel 1, this function only applies when the **SEt OPEr** function is set to **SCAN**. By pressing the **▲** or **▼** pushbutton at the **dCPE** function the decimal point position may be set. The display will indicate as follows: **0** (no decimal point), **0.1** (1 decimal place), **0.02** (2 decimal places) etc. up to 5 decimal places. Note if the decimal point is altered the channel will need to be recalibrated and alarm etc. settings checked.

5.20 Decimal point for channel 2

Display: **Ch 2dCPE**
Range: **0, 0.1** etc.
Default Value: **0**

Displays and sets the individual decimal point setting for input channel 2, operates in the same manner as channel 1 decimal point see **Ch 1dCPE** function 5.19.

5.21 Decimal point for channel 3

Display: **CH3dCPt**

Range: **0, 0.1** etc.

Default Value: **0**

Displays and sets the individual decimal point setting for input channel 3, operates in the same manner as channel 1 decimal point see **CH1dCPt** function 5.19.

5.22 Decimal point for channel 4

Display: **CH4dCPt**

Range: **0, 0.1** etc.

Default Value: **0**

Displays and sets the individual decimal point setting for input channel 4, operates in the same manner as channel 1 decimal point see **CH1dCPt** function 5.19.

5.23 Digital filter

Display: **FLtr**

Range: **0 to 8**

Default Value: **2**

Displays and sets the digital filter value. Digital filtering uses a weighted average method of determining the display value and is used for reducing display value variation due to short term interference. The digital filter range is selectable from **0** to **8**, where **0** = none and **8** = most filtering. Use **▲** or **▼** at the **FLtr** function to alter the filter level if required. Note that the higher the filter setting the longer the display may take to reach its final value when the input is changed, similarly the relay operation and any output options will be slowed down when the filter setting is increased. To set the digital filter value go to the **FLtr** function and use the **▲** or **▼** push buttons to set the required value then press **F** to accept this selection.

5.24 Printer output time period

Display: **PRnt SECS**

Range: **1 to 7200**

Default Value: **1**

The display values for the active input channels can be sent in ASCII format from the serial port at programmable regular time periods for output to a serial printer, PLC or computer. The **PRnt SECS** function allows the time period for the print output to be set. The available range is from 1 to 7200 seconds. For example if set to 10 seconds the channel information will be sent via the serial port every 10 seconds. To access and use this output method the **0.Prnt** function must be set to **t.Prnt**.

A typical format for four active channels in scanning mode is:

CH1 855, CH2 845, CH3 859, CH4 845

A typical format for four active channels in arithmetic mode is:



TOTAL 3404, CH1 855, CH2 845, CH3 859, CH4 845

Each output string is preceded by a start of text character <STX> and ends in a carriage return <CR>.

5.25 Set operation mode

Display: **SET OPER**
Range: **ARITH** or **SCAN**
Default Value: **ARITH**



Two basic modes are available namely:

Arithmetic mode (ARITH) - the default display (channel 0) shows the arithmetic sum of all the active channels i.e. if all four channels are selected then the result is channel 1 plus channel 2 plus channel 3 plus channel 4. Each channel can be individually viewed via the  and  buttons.

Scanning mode (SCAN) - the instrument will scan all active channels and display them in turn. The scan can be set by the user via the **SCAN PERIOD** function 5.26.

5.26 Scan period for SCAN mode

Display: **SCAN PERIOD**
Range: **0** to **240** seconds
Default Value: **0**

This function sets the automatic scanning period for display rotation i.e. display shows first channel preceded by the display **CH 1** then after the number of seconds set by this function will automatically move to the next channel etc. If set to **0** the display will not automatically scan and will remain on the channel selected. Even when set to **0** the instrument is still scanning all channels internally. At any time the  or  buttons can be used to select the channel viewed.

5.27 Number of channels to scan for SCAN mode

Display: **SCAN CHLS**
Range: **1** to **4**
Default Value: **4**

Displays and sets the number of active channels and can be set from **1** (one channel input only) to **4** (all four available channels active). If set to less than **4** the functions for the non active channels will not be seen on the display.

5.28 Sample rate

Display: ***FRtE***
Range: ***5 . 10 . 15 . 20 . 30 . 40*** or ***50***
Default Value: ***10***

Displays and sets the input sample rate from 5 to 50 samples per second. For example if set to ***10*** each active channel is sampled 10 times per second. Note: the display updates approx. 4 times per second. The faster sample rates can be utilised in features such as peak hold, peak/valley memory, analog or digital retransmission and serial communications.

5.29 mV/V input range for channel 1

Display: ***FR9.1***
Range: ***0.5 . 1.0 . 2.5 . 5.0 . 10 . 25 . 50*** or ***100***
Default Value: ***2.5***

Displays and sets the mV/V (milli Volt output per Volt of excitation) range to suit the transducer useable range. For example a transducer with 2mV/V output will have a theoretical output from 0mV at no load to 20mV at full specified load if 10V excitation is used. Check the transducer label or transducer calibration sheet or brochure for mV/V specification. Choose the value equal to or the next higher value to the mV/V output of the transducer. This selection sets the input range for the A/D converter. If too low a range is selected a “- - -” error message may be seen on the display when a load is applied. If too high a range is selected the full resolution capability will not be used and problems with calibration can result - see “Error messages” section.

5.30 mV/V input range for channel 2

Display: ***FR9.2***
Range: ***0.5 . 1.0 . 2.5 . 5.0 . 10 . 25 . 50*** or ***100***
Default Value: ***2.5***

Displays and sets the mV/V (milli Volt output per Volt of excitation) range to suit the transducer useable range. See function 5.30 for further description.

5.31 mV/V input range for channel 3

Display: ***FR9.3***
Range: ***0.5 . 1.0 . 2.5 . 5.0 . 10 . 25 . 50*** or ***100***
Default Value: ***2.5***

Displays and sets the mV/V (milli Volt output per Volt of excitation) range to suit the transducer useable range. See function 5.30 for further description.

5.32 mV/V input range for channel 4

Display: **779.4**
Range: **0.5 . 1.0 . 2.5 . 5.0 . 10 . 25 . 50** or **100**
Default Value: **2.5**

Displays and sets the mV/V (milli Volt output per Volt of excitation) range to suit the transducer useable range. See function 5.30 for further description.

5.33 Remote input function

Display: **F: NP**
Range: **NONE . P.HLd . d.HLd . H . Lo . H, Lo . tARF . 2EFD . SP.Ac . No.Ac .**
I.CAL . btch or **dULL**
Default Value: **NONE**

Remote input 1 function - When the remote input 1 terminals are short circuited, via a switch, relay, keyswitch etc. the instrument will perform the selected remote input function. A message will flash to indicate which function has been selected when the remote input pins are short circuited. The remote input functions are as follows:

NONE - no remote function required i.e. activating the remote input has no effect.

P.HLd - peak hold. The display will show the peak value (highest positive value) only whilst the remote input terminals are short circuited i.e. the display value can rise but not fall whilst the input terminals are short circuited. The message **P.HLd** will appear briefly every 8 seconds whilst the input terminals are short circuited to indicate that the peak hold function is active. All channels will be affected by this function including the arithmetic result when arithmetic mode is used.

d.HLd - display hold. The display value will be held whilst the remote input terminals are short circuited. The message **d.HLd** will appear briefly every 8 seconds whilst the input terminals are short circuited to indicate that the display hold function is active. All channels will be affected by this function including the arithmetic result when arithmetic mode is used.

H - peak memory. The peak value stored in memory will be displayed if the remote input terminals are short circuited, if the short circuit is momentary then the display will return to normal measurement after 20 seconds. If the short circuit is held for 2 to 3 seconds or the power is removed from the instrument then the memory will be reset. All channels will be affected by this function including the arithmetic result when arithmetic mode is used.

Lo - valley memory. The minimum value stored in memory will be displayed. Otherwise operates in the same manner as the **H** function described above. All channels will be affected by this function including the arithmetic result when arithmetic mode is used.

H, Lo - toggle between **H** and **Lo** displays. This function allows the remote input to be used to toggle between peak and valley memory displays. The first operation of the remote input will cause the peak memory value to be displayed, the next operation will give a valley memory display. **PH** or **PLo** will flash before each display to give an indication of display type. All channels will be affected by this function including the arithmetic result when arithmetic mode is used.

TARE - display tare for arithmetic result. Short circuiting the remote input pins momentarily will allow toggling between nett and gross values (shown as **NETT** and **GROSS**). If the remote input is short circuited for approx. 2 seconds the display will be tared and will show zero. The tare will be lost if power is removed. The tare operation can only be used to tare channel 0 i.e. the arithmetic sum.

ZERO - display zero. Zeroes the display in same manner as the tare function except that the zero is not lost when power is removed and the display will zero as soon as the remote input is shorted. When the **ZERO** operation is used the gross value cannot be recalled and the input at the time of the **ZERO** operation will become the new zero point. In arithmetic mode the sum and all active channels will be zeroed. In scanning mode only the channel viewed at the time of the zero operation will be zeroed.

SP.Ac - setpoint access only. This blocks access to any functions except the alarm setpoint functions unless the remote input pins are short circuited or entry is made via **CAL** mode or if the **ACCESS** function is set to **ALL**.

No.Ac - no access. This blocks access to all functions unless the remote input pins are short circuited or entry is made via **CAL** mode or if the **ACCESS** function is set to **ALL**.

I.CAL - Initiate auto calibration - not available on all software versions - this function allows the user to select when an auto calibration takes place rather than relying on the instruments normal internal calibration which may cause the output to pause. Closing the external input will cause an internal calibration to take place. If the input is held closed then an internal calibration will take place periodically.

batch - the batch function does not affect the display value when operated. It does, however affect the retransmission and alarm functions, see functions 5.79 and 5.83.

dull - display brightness control. The remote input can be used to change the display brightness. When this mode is selected the display brightness can be switched, via the remote input terminals, between the brightness level set at the **brgt** function and the brightness level set at the **dull** function.

5.34 Remote input two function

Display: **r.1 n2**
Range: Same as **r.1 nP**
Default Value: **NONE**

Remote input two function - As per **r.1 nP** function but uses remote input 2.

5.35 Remote input three function

Display: **r.1 n3**
Range: Same as **r.1 nP**
Default Value: **NONE**

Remote input three function - As per **r.1 nP** function but uses remote input 3.

5.36 **P** button function

Display: **Pbut**
Range: **NONE.H,Lo.H,Lo,tARE.ZEFO** or **btch**
Default Value: **NONE**

The front panel **P** button may be set to operate some of functions also available via the remote input, see **FI NP** 5.33 for a description of these functions. If both the remote input and **P** button function are operated simultaneously the **P** button will override the remote input. The functions below are as described in the **FI NP** function 5.33. Functions available are: **NONE.H,Lo.H,Lo,tARE.ZEFO** or **btch** Note: To prevent accidental operation of the **P** button in the **tARE** or **ZEFO** functions it is necessary to hold the button in for 2 seconds to perform the selected operation.

5.37 Access mode

Display: **ACCS**
Range: **OFF.EASY.NONE** or **ALL**
Default Value: **OFF**

The access mode function **ACCS** has four possible settings namely **OFF.EASY.NONE** and **ALL**. If set to **OFF** the mode function has no effect on alarm relay operation. If set to **EASY** the “easy alarm access” mode will be activated, see page 21. If set to **NONE** there will be no access to any functions via **FUNC** mode, entry via **CAL** mode must be made to gain access to alarm and calibration functions. If set to **ALL** then access to all functions, including calibration functions, can be gained via **FUNC** mode.

5.38 Setpoint access mode

Display: **SPAC**
Range: **A1,A1-2,A1-3** or **A1-4**
Default Value: **A1**

Setpoint access. Sets the access via **FUNC** mode and “easy alarm access” mode to the alarm relay setpoints. The following choices are available:

- A1** - Allows setpoint access to alarm 1 only.
- A1-2** - Allows setpoint access to alarms 1 and 2.
- A1-3** - Allows setpoint access to alarms 1,2 and 3.
- A1-4** - Allows setpoint access to alarms 1,2,3 and 4.

A remote input function (**FI NP**, **FI N2** or **FI N3**) must be set to **SPAC** for this function to operate. Note: Only the setpoints which have been given a value will be accessible e.g. if **A1H** is set to **OFF** then there will be no access to the **A1H** function when **SPAC** is used.

5.39 Lineariser points for channel 1

Display: **L, n P t 5.1**
Range: **2, 3 or 4**
Default Value: **2**

Displays and sets the number of calibration scaling points to be used. Up to 4 individual calibration scaling points can be selected to allow for correction of a non linear input signal. Note that when more than 2 calibration points are used the **ECAL** method of calibration cannot be used and the **ECAL** functions will not be seen.

5.40 Lineariser points for channel 2

Display: **L, n P t 5.2**
Range: **2, 3 or 4**
Default Value: **2**

Displays and sets the number of calibration scaling points to be used. Up to 4 individual calibration scaling points can be selected to allow for correction of a non linear input signal. Note that when more than 2 calibration points are used the **ECAL** method of calibration cannot be used and the **ECAL** functions will not be seen.

5.41 Lineariser points for channel 3

Display: **L, n P t 5.3**
Range: **2, 3 or 4**
Default Value: **2**

Displays and sets the number of calibration scaling points to be used. Up to 4 individual calibration scaling points can be selected to allow for correction of a non linear input signal. Note that when more than 2 calibration points are used the **ECAL** method of calibration cannot be used and the **ECAL** functions will not be seen.

5.42 Lineariser points for channel 4

Display: **L, n P t 5.4**
Range: **2, 3 or 4**
Default Value: **2**

Displays and sets the number of calibration scaling points to be used. Up to 4 individual calibration scaling points can be selected to allow for correction of a non linear input signal. Note that when more than 2 calibration points are used the **ECAL** method of calibration cannot be used and the **ECAL** functions will not be seen.

5.43 Channel 1 first live input calibration point

Display: **CH1CAL 1**

Range: n/a

Default Value: n/a

This function together with the second and optional third and fourth scaling point functions displays and sets the independent calibration/scaling points of the channel 1 input to the display. The number of calibration points for each channel can be individually set e.g. by the **LnPTS. 1** function for channel 1. With this calibration method different live inputs (weights or pressures etc.) are applied to the cell/sensor and the instrument is scaled to each these inputs in turn. For a 2 point calibration it is recommended that a change of at least 20% of the capacity of the cell is applied between calibration points. Ideally 100% of capacity should be used with 10% being the minimum change before a calibration error message is seen.

Note if more than 2 points are used it is essential that inputs are carried out sequentially starting with the first point followed by the second etc. and that the higher points are more positive and are at least 10% of full scale higher than the previous points i.e. it is essential that the input is increasing in a positive direction. If an input is more negative than the previous calibration input an error message **SCALE Err** will be seen when the calibration attempt is made.

The calibration of these points may also be carried out as independent operations i.e. **CH1CAL 1** and **CH1CAL2** points may be changed independently e.g. if it is not possible to perform **CH1CAL2** directly after the **CH1CAL 1** function then the **CH1CAL2** may be performed at a later time although the display will not be showing calibrated readings until the process is completed. If more than two points are selected then this only applies if the points are changed in sequence i.e. if a single point is calibrated out of sequence the calibration scaling will be corrupted.

Alternative methods of calibration scaling for channel 1 input are the **CH1ECAL** function, the **CH1OFFSE** function.

The procedure for a live input calibration is as follows:

- When the **CH1CAL 1** function is reached press the **▲** and **▼** push buttons simultaneously, then release them.
- The display will flash **CH1CAL 1** followed by a “live” reading from the input. Apply a known weight to the load cell or pressure to the pressure sensor e.g. zero load or pressure.
- When the “live” reading is steady (do not worry if this is not the reading required) press then release the **F** push button.
- The display will flash **CH1SCALE 1** followed by the last scale value in memory. Use the **▲** or **▼** push button to alter this value to the required reading i.e. the display value required for the load now on the load cell or the pressure from the pressure sensor.
- Press, then release, the **F** push button. The display will now indicate **CAL End** followed by **CH1CAL2**.
- Press both the **▲** and **▼** push buttons simultaneously, then release them. The display will flash **CH1CAL2** followed by a “live” reading from the input. Apply a different known weight to the load cell or pressure to the pressure sensor. For best accuracy this second weight or pressure should be as close as possible to the normal full load weight or pressure for the system.

- When the “live” reading is steady (do not worry if this is not the reading required) press, then release the **F** push button.
- The display will flash **CH1SCL2** followed by the last scale value in memory. Use the **▲** or **▼** push button to alter this value to the required reading i.e. the display value required for the load now on the load cell or pressure on the pressure sensor.
- Press, then release, the **F** push button. The display will now indicate **CAL End** and the instrument will now move on to the next function.
- Repeat the process for the remaining calibration points if more than two points are used

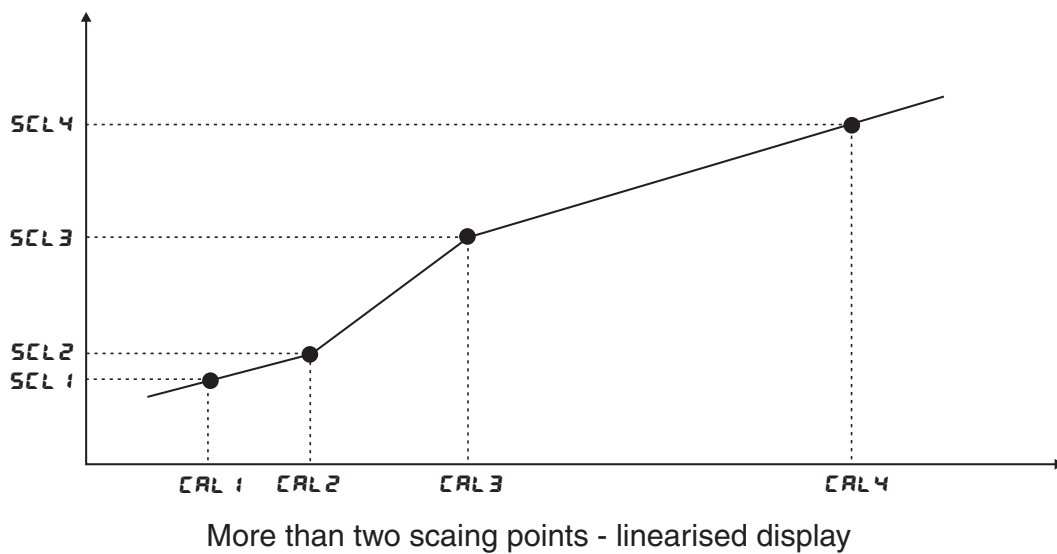
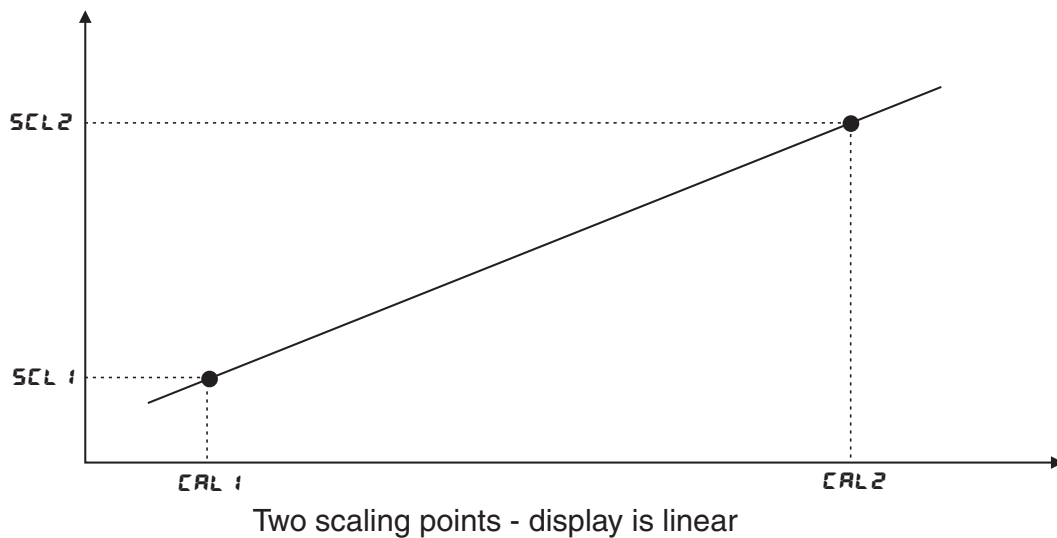

5.44 Channel 1 second live input calibration point

Display: **CH1CAL2**
 Range: n/a
 Default Value: n/a

Displays and sets the second live input calibration scaling point for channel 1. See **CH1CAL1** function 5.43 for description.

5.45 Channel 1 third live calibration point

Display: **CH1CAL3**
Range: Any display value
Default Value: n/a

Calibration scaling third point, seen only when **Lin Pts. 1** is set to **3** or **4**. See **CH1CAL1** function 5.43 for description.

5.46 Channel 1 fourth live calibration point

Display: **CH1CAL4**
Range: Any display value
Default Value: n/a

Calibration scaling fourth point, seen only when **Lin Pts. 1** is set to **4**. See **CH1CAL1** function 5.43 for description.

5.47 Channel 2 first live input calibration point

Display: **CH2CAL1**
Range: n/a
Default Value: n/a

Displays and sets the first live input calibration scaling point for channel 2. Setup is the same as **CH1CAL1** and **CH1CAL2** functions, see function 5.43 for description.

5.48 Channel 2 second live input calibration point

Display: **CH2CAL2**
Range: n/a
Default Value: n/a

Displays and sets the second live input calibration scaling point for channel 2. Setup is the same as **CH1CAL1** and **CH1CAL2** functions, see function 5.43 for description.

5.49 Channel 2 third live calibration point

Display: **CH2CAL3**
Range: Any display value
Default Value: n/a

Calibration scaling third point, seen only when **Lin Pts. 2** is set to **3** or **4**. See **CH1CAL1** function 5.43 for description.

5.50 Channel 2 fourth live calibration point

Display: CH2CAL4
Range: Any display value
Default Value: n/a

Calibration scaling fourth point, seen only when **L, n Pt5.2** is set to **4**. See **CH1CAL1** function 5.43 for description.

5.51 Channel 3 first live input calibration point

Display: CH3CAL1
Range: n/a
Default Value: n/a

Displays and sets the first live input calibration scaling point for channel 3. Setup is the same as **CH1CAL1** and **CH1CAL2** functions, see function 5.43 for description.

5.52 Channel 3 second live input calibration point

Display: CH3CAL2
Range: n/a
Default Value: n/a

Displays and sets the second live input calibration scaling point for channel 3. Setup is the same as **CH1CAL1** and **CH1CAL2** functions, see function 5.43 for description.

5.53 Channel 3 third live calibration point

Display: CH3CAL3
Range: Any display value
Default Value: n/a

Calibration scaling third point, seen only when **L, n Pt5.3** is set to **3** or **4**. See **CH1CAL1** function 5.43 for description.

5.54 Channel 3 fourth live calibration point

Display: CH3CAL4
Range: Any display value
Default Value: n/a

Calibration scaling fourth point, seen only when **L, n Pt5.3** is set to **4**. See **CH1CAL1** function 5.43 for description.

5.55 Channel 4 first live input calibration point

Display: **CH4CAL1**

Range: n/a

Default Value: n/a

Displays and sets the first live input calibration scaling point for channel 4. Setup is the same as **CH1CAL1** and **CH1CAL2** functions, see function 5.43 for description.

5.56 Channel 4 second live input calibration point

Display: **CH4CAL2**

Range: n/a

Default Value: n/a

Displays and sets the second live input calibration scaling point for channel 4. Setup is the same as **CH1CAL1** and **CH1CAL2** functions, see function 5.43 for description.

5.57 Channel 4 third live calibration point

Display: **CH4CAL3**

Range: Any display value

Default Value: n/a

Calibration scaling third point, seen only when **LivePt5.4** is set to **3** or **4**. See **CH1CAL1** function 5.43 for description.

5.58 Channel 4 fourth live calibration point

Display: **CH4CAL4**

Range: Any display value

Default Value: n/a

Calibration scaling fourth point, seen only when **LivePt5.4** is set to **4**. See **CH1CAL1** function 5.43 for description.



5.59 Channel one mV/V input scaling

Display: **CH1CAL**

Range: **-32.000** to **32.000**

Default Value: n/a

Note: this function will not be seen if more than 2 calibration points are selected.

This alternative channel 1 calibration method allows the known mV/V and full scale value of the load cell to be entered as the calibration value i.e. no live inputs are required. The mV/V value is entered to 3 decimal places. At the **CH1CAL** function press then release  and .

simultaneously to enter the **CH1ECAL** function, the display will indicate the last stored mV/V value, use the **▲** or **▼** push button to change this display to the mV/V output for your cell. Press and release the **F** push button, the display will now indicate **CH1ESCL** followed by the previous full scale value in memory, use the **▲** or **▼** push button to change this to the required full scale reading. For example a 10 kilogram, 2.000mV/V load cell is used, it is know that at the maximum rated load (10kg) the display is to be scaled to read **10.00**, once the **ECAL** function has been entered for the required channel change the mV/V value **2.000** and the **ESCL** setting to **10.00**. Once the **ESCL** value has been entered use the **SET ZERO** function with zero weight (or the deadweight) on the load cell to give the instrument a zero reference or use the offset calibration function for the channel required to give an offset reference point.

The **ECAL** value set must be within the value set at the **RANGE** function for that channel e.g. you cannot set the **ECAL** to **2.000** if the **RANGE** function is set to **1.000**, if an attempt is made to make such an entry an **ADC RANGE Err** message will be seen. The maximum positive and negative values to which the **ECAL** value can be successfully set are **-32.000** to **32.000** this applies even when the **RANGE** setting is **100**. If an input with a higher mV/V output is being used then the **ECAL** and **ESCL** values can be set in correct ratios to accomplish the requires setting e.g. an **ECAL** value of **50.000** and **ESCL** of **1000** cannot be set but an **ECAL** of **25.00** and **ESCL** of **500** will set the same calibration slope and will give the correct reading at 50.000mV/V input.

Use of **ECAL** and **ESCL** as reference values.

When using the two point calibration method (method 1), as previously described, the mV/V value is automatically calculated and may be viewed at the required channel **ECAL** function (**CH1ECAL** and **CH1ESCL** etc.). The **ECAL** and **ESCL** values may be recorded and used to re calibrate the instrument to the same load cell input at a later date. This is particularly useful when the calibration has been accidentally altered and repeating the “live input” calibration is not practical. Note that the **ECAL** value calculated by this method will match the known mV/V value only if **CAL2** was carried out at exactly the full rated load of the load cell. For example if a 2mV/V 10kg load cell is calibrated on input 3 using live inputs with zero load used as the **CH3CAL1** input and a 5kg load is used as the **CH3CAL2** input then when the **CH3ECAL** value is viewed the value seen should be approximately 1.000mV/V. This is half the actual mV/V output of the cell because a half full scale load (5kg) was used. The **CH3ESCL** value will match the **CH3ESCL2** value.

5.60 Channel two mV/V input scaling

Display: **CH2 ECAL**
 Range: **-32.000** to **32.000**
 Default Value: n/a

This alternative channel 2 calibration method allows the known mV/V and full scale value of the load cell to be entered as the calibration value. See function **CH1ECAL** for description.

5.61 Channel three mV/V input scaling

Display: **CH3 ECAL**
 Range: **-32.000** to **32.000**
 Default Value: n/a

This alternative channel 3 calibration method allows the known mV/V and full scale value of the

load cell to be entered as the calibration value. See function **CH1ECAL** for description.

5.62 Channel four mV/V input scaling

Display: **CH4ECAL**
Range: **-32.000** to **32.000**
Default Value: n/a

This alternative channel 4 calibration method allows the known mV/V and full scale value of the load cell to be entered as the calibration value. See function **CH1ECAL** for description.

5.63 Channel 1 set zero

Display: **CH1ZEF0**
Range: n/a
Default Value: n/a

This function may be used to set the channel to a display reading of zero. The set zero point is entered when the load cell is installed and in a no weight condition. To operate the set zero function press then release the **▲** and **▼** simultaneously the display will show a value, press the **F** push button to accept this as a zero input or press the **P** push button to abort the function if you do not wish to accept this as the new zero. The display will indicate **ZEF0 End** if the **F** button was pressed. The zero point will be retained even if power is removed.

5.64 Channel 2 set zero

Display: **CH2ZEF0**
Range: n/a
Default Value: n/a

This function may be used to set the channel to a display reading of zero. See function **CH1ZEF0** for description.

5.65 Channel 3 set zero

Display: **CH3ZEF0**
Range: n/a
Default Value: n/a

This function may be used to set the channel to a display reading of zero. See function **CH1ZEF0** for description.

5.66 Channel 4 set zero

Display: **CH4 ZER0**
Range: n/a
Default Value: n/a

This function may be used to set the channel to a display reading of zero. See function **CH1ZER0** for description.

5.67 Channel 1 calibration offset

Display: **CH1 OFFSt**
Range: Any display value
Default Value: n/a

Allows the channel calibration to be offset by a single point value. This value is added or subtracted across equally the range of the instrument and so it is suitable for use only when the entire range of display values for that channel is to be adjusted. With a known load on the cell press, then release **▲** and **▼** simultaneously to enter the zero function, the current reading will be displayed. Press then release the **F** push button, the channel number followed by **SCLE** will then be briefly displayed followed by a reading, alter the reading on the display (via the **▲** or **▼** pushbutton) to give the required reading for the load. Press, then release the **F** push button, the channel number followed by **OFFSt End** will be displayed and the display will move on to the next function. Note that the offset operation is affected by the zero range operation. If a **ZER0 RANGE Err** message is seen this means that the offset or accumulated offsets have gone beyond the limits set by each channels zero range function.

5.68 Channel 2 calibration offset

Display: **CH2 OFFSt**
Range: Any display value
Default Value: n/a

Allows the channel calibration to be offset by a single point value. See function **CH1 OFFSt** for details.

5.69 Channel 3 calibration offset

Display: **CH3 OFFSt**
Range: Any display value
Default Value: n/a

Allows the channel calibration to be offset by a single point value. See function **CH1 OFFSt** for details.

5.70 Channel 4 calibration offset

Display: **CH4 OFFSE**
Range: Any display value
Default Value: n/a

Allows the channel calibration to be offset by a single point value. See function **CH1 OFFSE** for details.

5.71 Channel 1 zero range

Display: **CH1 Z.RNG**
Range: - 1999 to 9999 or **OFF**
Default Value: **1000**

The zero range function allows a limit value to be set above which the display will not zero i.e. if a zero operation is attempted on channel 1 via the **P** button, remote input or set zero function when the display value for channel 1 is greater than the zero range setting the display will refuse to zero and give a **ZERO RANGE Err** message. For example if the zero range setting is **10** the instrument will only respond to a zero operation if the display reading at the time for channel 1 is between **- 10** and **10**. If the zero range function is not required it can be set to **OFF** by pressing the **▲** and **▼** buttons simultaneously at this function. When switched off the instrument can be zeroed no matter what the display value. Note that the instrument keeps track of the value being zeroed at each operation, when the total amount zeroed from repeated operations becomes greater than the zero range value the instrument will reject the zero operation and a **ZERO RANGE Err** message will be seen. If repeated zero operations are required the **ZERO RANGE** function should be set to **OFF** or alternatively the **SAFE** operation could be considered rather than the **ZERO**. Note that the offset functions performed either from the front panel pushbuttons or via Modbus serial communications will also be affected by the zero range function and will give the same display error message if the offset or accumulated offset is outside the range.

5.72 Channel 1 zero reference

Display: **CAL Z.Ch 1**
Range: Any display value
Default Value: n/a

The calibration zero can be used to select a zero reference point for the **Ch 1 Z.RNG** (Zero Range) function. This calibration zero function is used only as a reference input for the zero range function and does not affect the display value or calibration of the display. For example if the **CAL ZERO** operation is carried out with a display reading of **500** and a **ZERO RANGE** reading of **10** the zero range function will allow the display to zero only if the current display reading is between **490** and **510**.

5.73 Channel 2 zero range

Display: **CH2 2.rng**
Range: **- 1999 to 9999 or OFF**
Default Value: **1000**

The zero range function allows a limit value to be set above which the display will not zero. See function **CH 1 2.rng** for description.

5.74 Channel 2 zero reference

Display: **CAL 2.Ch2**
Range: Any display value
Default Value: n/a

The calibration zero can be used to select a zero reference point for the **Ch2 2.rng** function. See function **CAL 2.Ch 1** for description.

5.75 Channel 3 zero range

Display: **CH3 2.rng**
Range: **- 1999 to 9999 or OFF**
Default Value: **1000**

The zero range function allows a limit value to be set above which the display will not zero. See function **CH 1 2.rng** for description.

5.76 Channel 3 zero reference

Display: **CAL 2.Ch3**
Range: Any display value
Default Value: n/a

The calibration zero can be used to select a zero reference point for the **Ch3 2.rng** function. See function **CAL 2.Ch 1** for description.

5.77 Channel 4 zero range

Display: **CH4 2.rng**
Range: **- 1999 to 9999 or OFF**
Default Value: **1000**

The zero range function allows a limit value to be set above which the display will not zero. See function **CH 1 2.rng** for description.

5.78 Channel 4 zero reference

Display: **CAL 2.Ch4**
Range: Any display value
Default Value: n/a

The calibration zero can be used to select a zero reference point for the **Ch4 2.rn9** function. See function **CAL 2.Ch 1** for description.

5.79 Alarm relay 1 operation mode

Display: **A 1**
Range: **LIVE, Ch 1 Ch2, Ch3, Ch4, TARE, btch, bch2, P.HLd, d.HLd, Hi, Lo or di SP**
Default Value: **LIVE**

The alarm mode function (**A1** to **A4**) allows the alarm relay to follow one of the following modes of operation.

The live total display (**Ch0**) value (**LIVE**), channel 1 value (**Ch 1**), channel 2 value (**Ch 2**), channel 3 value (**Ch 3**), channel 4 value (**Ch 4**), the tare value (**TARE**), the batch value (**btch**), the alternative batch operation (**bch2**), the peak hold value (**P.HLd**), the display hold value (**d.HLd**), the peak memory (**Hi**), the valley memory (**Lo**) or the display value (**di SP**). The tare and batch operations require a remote input to be set, see the **FINP** function. Ensure that the **FINP**, **FIN2** or **FIN3** function is set to tare or batch as required.

Example 1- **A1** is set to **LIVE**.

With the alarm function set to follow the total (**Ch0** arithmetic mode) display value the alarm will activate at the alarm high/low settings. Thus if **A1Lo** is set to **50** and **A1Hi** is set to **100** then alarm 1 will activate if the total reading falls below 50 or goes above 100.

Example 2 - **A1** is set to **TARE** and **FINP** (remote input special function) is set to **TARE**. Assume that **A1Hi** is set to **100** and that the instrument is given a remote tare when the display reads **40**. Once the instrument is tared the display will read **0**. Alarm 1 is set to follow the tare value and will therefore operate when the (nett) display becomes greater than **100**. Note: If the instrument had been tared when **A1** was set to **di SP** then the alarm will follow the gross value not the tared value and will operate if the nett display is above **60** (i.e. the gross value is above 100). The low alarm setting operates in the same manner e.g. if **A1Lo** was set to **100** and the display was tared at a reading of **40** then the low alarm would operate when the display reads **60** or below.

Example 3 - **A1** is set to **Ch3**. Assume that **A1Hi** is set to **500**. If the channel 3 value reaches **500** the relay will activate.

Example 4 - **A1** is set to **btch** and **FINP** is set to **btch** - operates only from total (**Ch0**) in arithmetic mode.

In this **btch** mode the relay activates when the batch value is reached following receipt of a batch input.

Assume that **A1Hi** is set to **250** and that the instrument is given a remote batch input when the display reads **70**. The display will show the message **btch**, the value shown does not alter when a batch input is applied but alarm 1 will not trip until the display goes above **320** (**250** plus **70**). i.e. once the batch input is applied the display value must increase by the alarm value

before the alarm will trip. The low alarm setting operates in the same manner e.g. if **A1Lo** was set to **-10** and a remote batch input was applied at a reading of **70** then the low alarm would operate when the display reads **60** or below.

Example 5 - Alternative batch operation - **A1** is set to **bch2** and **F1NP** is set to **bch** - operates only from total (**CHO**) in arithmetic mode.

In this **bch2** mode the relay activates on receiving a batch input and resets when the batch value is reached.

Assume that **A1H** is set to **250** and that the instrument is given a remote batch input when the display reads **70**. The display will show the message **bch**, the value shown does not alter when a batch input is applied but relay 1 will trip once the batch input is received and will not reset until the display goes above **320** (**250** plus **70**). i.e. once the batch input is applied the display value must increase by the alarm value before the relay will reset. The low alarm setting operates in the same manner e.g. if **A1Lo** was set to **-20** and a remote batch input was applied at a reading of **70** then the relay would activate on receipt of a batch input and reset when the display reads **50** or below.

In this mode the trip time, reset time and hysteresis functions are all disabled but the free fall values can still be set, the low alarm settings must always be negative values and the high alarm settings must always be positive values. If a free fall value is used on a high alarm then the relay will reset at the relay batch value minus the free fall value. If a free fall value is used on a low alarm then the relay will reset at the batch value plus the free fall value.

Example 6 - **A1** is set to **P.HLd** and **F1NP** is set to **P.HLd** - operates only from total (**CHO**) in arithmetic mode. If **A1H** is set to **100** then it will operate whenever the display shows a value over 100. If the peak value exceeds 100 when the remote input is closed then alarm 1 will activate and will not reset until the remote input opens and the display value falls below 100.

Example 7 - **A1** is set to **d.HLd** and **F1NP** is set to **d.HLd** - operates only from total (**CHO**) in arithmetic mode. If **A1Lo** is set to **5** then it will operate whenever the display shows a value below 5. If the display hold remote input is operated at a value above 5 then the alarm will not activate whilst the remote input remains closed, no matter what the electrical input. Likewise if the remote input is operated at a value below 5 then alarm will not de activate until the remote input is opened and the display value goes above 5.

Example 8 - **A1** is set to **H** and **F1NP** is set to **H** - operates only from total (**CHO**) in arithmetic mode. If **A1H** is set to **50** and the peak memory value becomes greater than 50 then alarm 1 will be constantly activated at this point and will only become de activated when the memory is reset at a value below 50. The memory can be reset by holding the remote input closed for 2-3 seconds. Note that in this case the alarm can be activated even if the display value is less than the alarm setting, this is because the alarm is activated by the value in peak memory rather than the display value.

Example 9 - **A1** is set to **Lo** and **F1NP** is set to **Lo** - operates only from total (**CHO**) in arithmetic mode. If **A1Lo** is set to **280** and the valley memory value becomes less than 280 then alarm 1 will be constantly activated at this point and will only become de activated when the memory is reset at a value above 280. The memory can be reset by holding the remote input closed for 2-3 seconds. Note that in this case the alarm can be activated even if the display value is greater than the alarm setting, this is because the alarm is activated by the value in valley memory rather than the display value.

5.80 Alarm relay 2 operation mode

Display: **A2**
Range: **L1 UE, Ch1 Ch2, Ch3, Ch4, tAFE, btch, bch2, P.HLd, d.HLd, Hi ,
Lo or di SP**
Default Value: **L1 UE**

Sets the alarm relay operation mode for relay 2. See function 5.79 for description and examples.

5.81 Alarm relay 3 operation mode

Display: **A3**
Range: **L1 UE, Ch1 Ch2, Ch3, Ch4, tAFE, btch, bch2, P.HLd, d.HLd, Hi ,
Lo or di SP**
Default Value: **L1 UE**

Sets the alarm relay operation mode for relay 3. See function 5.79 for description and examples.

5.82 Alarm relay 4 operation mode

Display: **A4**
Range: **L1 UE, Ch1 Ch2, Ch3, Ch4, tAFE, btch, bch2, P.HLd, d.HLd, Hi ,
Lo or di SP**
Default Value: **L1 UE**

Sets the alarm relay operation mode for relay 4. See function 5.79 for description and examples.

5.83 Analog output operation mode

Display: **FEC**
Range: **L1 UE, Ch1 Ch2, Ch3, Ch4, tAFE, btch, bch2, P.HLd, d.HLd, Hi ,
Lo or di SP**
Default Value: **L1 UE**

Sets the analog output operation mode, this operates in a similar manner same manner as the alarm relay operation modes. See function 5.79 for description and examples. In batching mode the **FEC-** and **FEC~** functions set the batch value and the output will drop to 4mA when the batch input is activated.

5.84 Data logger logging period

Display: **Log UPdt**
Range: **0.10 to 60.00**
Default Value: **1.00**

Select log update time - seen only with data logger option. Refer to the separate “TP4-WT Serial Communications Output Addendum” booklet for further details.

Displays and sets the time period between each log sample. Available selections are:

0.10 (10 seconds), 0.20 (20 seconds), 0.30 (30 seconds), 1.00 (1 minute), 2.00 (2 minutes), 3.00 (3 minutes), 4.00 (4 minutes), 5.00 (5 minutes), 6.00 (6 minutes), 10.00 (10 minutes), 15.00 (15 minutes), 20.00 (20 minutes), 30.00 (30 minutes) and 60.00 (60 minutes).

Note: The data log memory (see **Clr Log** below) must be cleared whenever the log update time is changed or the date and time is changed.

5.85 Clear data logger memory

Display: **Clr Log**
Range: **0.10** to **60.00**
Default Value: n/a

Clear data log memory - seen only with data logger option. Refer to the separate “TP4-WT Serial Communications Output Addendum” booklet for further details.

This function clears the data log memory, to clear the memory press then release **▲** and **▼** simultaneously, the display will show **Clr P** asking if you really want to clear the memory. If you wish to clear memory then press then release **▲** and **▼** simultaneously again. The log memory will then be cleared and the log period reset, the display will indicate **Prog Log** to confirm this. Once the memory is cleared all previously logged records will be lost from the instruments memory, if the **Clr P** message is reached and it is not wished to clear the log memory then pressing and releasing either **F** or **P** will abort the function.

5.86 Set datalogger clock

Display: **SEt tEtE**
Range: **0.01** to **24.00**
Default Value: n/a

Set time - seen only with data logger option. Refer to the separate “TP4-WT Serial Communications Output Addendum” booklet for further details.

Displays and sets the current time in hours and minutes (24 hour format HH.MM) e.g. set as **17.20** for 5:20 pm.

5.87 Set datalogger date

Display: **SEt dAtE**
Range: **01.01** to **31.12**
Default Value: Date

Set date - seen only with data logger option. Refer to the separate “TP4-WT Serial Communications Output Addendum” booklet for further details. Displays and sets the current date in days and months (DD.MM format). The months will roll over automatically (up at the end of the month, down at the beginning of the month) as the day is scrolled up or down.

5.88 Set datalogger year

Display: **SEt YEAR**
Range: **1970 to 2037**
Default Value: Year

Set year - seen only with data logger option. Refer to the separate “TP4-WT Serial Communications Output Addendum” booklet for further details. Displays and sets the current year (YYYY format). Valid years settings are from 1970 to 2037 (valid Julian time format years).

5.89 Baud rate for serial communications

Display: **bAUD**
Range: **300 . 600 . 1200 . 2400 . 4800 . 9600 . 19.2 or 38.4**
Default Value: **9600**

Select from **300 . 600 . 1200 . 2400 . 4800 . 9600 . 19.2k** or **38.4k** baud. When connected to the LD-SL slave display the baud rate must be set to 2400. Refer to the separate “TP4-WT4 Serial Communications Output Addendum” booklet for further details.

5.90 Parity for serial communications

Display: **Prty**
Range: **NONE . EVEN** or **odd**
Default Value: **NONE**

Select parity check to either **NONE**, **EVEN** or **odd**. When connected to the LD-SL slave display the parity must be set to **NONE**. Refer to the separate “TP4-WT4 Serial Communications Output Addendum” booklet for further details.

5.91 Output mode for serial communications

Display: **O.PUt**
Range: **dI SP . Cont . POLL . R.buS . ā.buS . t.Prty . C.ALL . NONE . dSP.4** or **dSP.6**
Default Value: **Cont**

Refer to the separate “TP4-WT Serial Communications Output Addendum” booklet for further details. Allows user to select the serial interface operation as follows:

dI SP - sends image data from the display without conversion to ASCII.

Cont - sends ASCII form of display data at a rate typically 90% of the sample rate.

POLL - controlled by computer or PLC as host. Host sends command via RS232/485 and instrument responds as requested.

R.buS - is a special communications mode used with Windows compatible optional PC download software. Refer to the user manual supplied with this optional software.

ā.buS - Modbus RTU

t.Prty Timed output - see **PFnt SECS** function.

C.ALL This mode operates in the same manner as the **Cont** mode except that all active channels

are transmitted. In scanning mode channel 1 is the First channel to be transmitted. In arithmetic mode operation the sum is transmitted first followed by channel 1 etc. A typical format for the data would be:

<STX> 90, 30, 0, 40, 20 <CR>

Where 90 is the sum, 30 is channel 1 value, 0 is channel 2 value etc.

NONE - no serial output.

dSP.4 - 4 digit slave display - use this setting when connecting to model LD-SL four digit slave display.

dSP.6 - 6 digit slave display - use this setting when connecting to model LD-SL six digit slave display.

5.92 Instrument address for serial communications

Display: ***Addr***
Range: ***0 to 31***
Default Value: ***0***

Set unit address for polled (***POLL***) mode (***0 to 31***). Allows several units to operate on the same RS485 interface reporting on different areas etc. The host computer or PLC may poll each unit in turn supplying the appropriate address. The unit address ranges from 0 to 31 (DEC) but is offset by 32 (DEC) to avoid clashing with ASCII special function characters (such as <STX> and <CR>). Therefore 32 (DEC) or 20 (HEX) is address 0, 42 (DEC) or 2A (HEX) is address 10. Refer to the separate “TP4-WT Serial Communications Output Addendum” booklet for further details.

5.93 Returning to normal measure mode

When the calibration has been completed it is advisable to return the instrument to the normal mode (where calibration functions are less likely to be tampered with). To return to normal mode, turn off power to the instrument, wait a few seconds and then restore power.

5.94 Error messages

The examples given below illustrate typical problems which may occur when setting up an instrument of this type.

1. Display shows “- - - -”, “-or-”, “***CAL ERR***” or “***SPAN ERR***” or “***tbLE Err***” message. The “- - - -” error message indicates that the mV/V input is higher than the instrument expects. Check that the ***RNGE*** function is set to the mV/V input which corresponds to the cell being used. The “-or-” error message indicates that the display value is too high to display e.g. a value greater than ***999999*** or less than ***-199999***, if the input is telling the display to indicate a number outside this range then the “-or-” error message will be displayed. Check the calibration values for this cell and ensure that the display is scaled within the range of the number of display digits. The “***CAL ERR***” error message indicates that one of the calibration points mV/V inputs was too high, again check the ***RNGE*** function.

The “***SPANERR***” message indicates that the calibration points are too close together, re calibrate and ensure that the calibration points are at least 2% of full scale apart.

The “***tbLE Err***” message indicates that more than two calibration points were chosen and that the live inputs were not applied in a positive going order i.e. the input applied was less positive than the previous calibration input.

2. A new set of calibration values have been entered but the display is not indicating correctly. Ensure when calibrating that the “live input” values shown at **CAL 1** and **CAL 2** were steady before being accepted. If they are not steady then the signals from the load cell need to be investigated for electrical noise.
3. Display value is fluctuating wildly. Check load cell connections. If a recent calibration change has been made check that the live inputs of at least 2% of full scale load difference were used.
4. Display resets itself during normal operation i.e. the “wake up” display messages seen when power is applied to the instrument appear on the display without power being removed. Check for voltage surges or drop outs on the power supply line, also check for gross electrical noise pickup (typical electrical noise sources are motors, generators, fluorescent lights, high voltage cables etc.) on the load cell wiring. The use of shielded cable is recommended for load cells used in situations where electrical noise is likely to be encountered. If power surges or dropouts are experienced then investigate the cause and rectify or place the instrument on another power circuit.

6 Specifications

6.1 Technical specifications

Input type:	Four ratiometric 4 arm mV/V strain gauge inputs (4 wire type). Multiple load cells may be connected to each input see "Bridge Compatability" below
Input sensitivity:	0.5mV/V to 100mV/V selectable in steps
Bridge compatibility:	80Ω to > 2000Ω depending on excitation voltage, minimum total load per input channel 80Ω at 5V and 160Ω at 10V (nominal figures)
Excitation:	5V or 10V link selectable
Accuracy:	Up to 0.005% of full scale (alarms and display) dependant upon sample rate selection. Including analog retransmission better than 0.1% system accuracy. Accuracy for ECAL and ESCL calibration method is 1%. On power up there may be up to $\pm 20\mu V$ zero offeset on each channel.
Sample Rate:	5 to 50 samples per sec selectable in steps
ADC resolution:	See resolution table which follows
Conversion Method:	Sigma Delta
Microprocessor:	HC68HC11F CMOS
Ambient temperature:	-10 to 60° C
Humidity:	5 to 95% non condensing
Display:	6 digit 20mm + 4 way keypad and annunciator LEDs
Power Supply:	AC 240V or 110V 50/60Hz or 12 to 48V DC or AC isolated supply Note: supply type is factory configured.
Power Consumption:	AC supply 15 VA max, DC supply typically 250mA at 12VDC or 160mA at 24VDC plus load cell current
Output (standard):	4 x relay, Form C, rated 5A resistive 240VAC 4-20mA analog output RS232 serial communications (non isolated)

6.2 Optional outputs

Serial communications:	Isolated RS485
Datalogger:	32k or 128k internal datalogger memory

6.3 Physical Characteristics

Case Size:	255mm x 145mm x 125mm
Panel Cut Out:	If using this method of mounting the panel cut out size is 240 x 130mm -0.0mm/+0.5mm
Connections:	Plug in screw terminals (max 1.5mm wire, 2.5mm for relays and power supply).
Weight:	1.3kgs

6.4 Resolution table

Note: Figures in the table apply when the digital filter setting is 0. Add 0.5 bits effective resolution for each step on the digital filter setting e.g. if the digital filter is set at 4, add 2 bits of effective resolution to each of the figures in the table.

Effective resolution (bits) over full scale							
Samples/sec.	mV/V input						
	0.5mV/V	1mV/V	2.5mV/V	5mV/V	10mV/V	25mV/V	50mV/V or 100mV/V
5	15.5	16.5	17.5	18.5	19.5	20.5	20.5
10	15.5	16.5	17.5	18.5	19.0	19.0	19.0
15	15.5	16.5	17.5	18.5	18.5	19.0	19.0
20	15.5	16.5	17.5	18.0	18.5	18.5	18.5
30	15.5	16.5	17.5	18.0	18.5	18.5	18.5
50	15.0	16.0	16.5	17.0	17.5	17.5	17.5

Resolution in μV can be calculated using the resolution in bits figures above. These μV resolution values are calculated by the following method:

Resolution (μV) = full signal input voltage range / number of divisions of resolution.

e.g. for 2.5mV/V range, 10V excitation, full signal input voltage is 2.5mV x 10V excitation = 25mV.

For 14.5 bits (100 samples/sec., zero filter) the number of divisions is $2^{14.5}$ which equals 23170 divisions.

For 21.5 bits (5 to 30 samples/sec, filter setting of 8) the number of divisions is 2965820 ($2^{21.5}$).

Resolution (μV) at 14.5 bits = (2.5 mV x 10) / 23170 = $1.08\mu\text{V}$

Resolution (μV) at 21.5 bits = (2.5 mV x 10) / 2965820 = $0.0084\mu\text{V}$

7 Guarantee and service

The product supplied with this manual is guaranteed against faulty workmanship for a period of two years from the date of dispatch.

Our obligation assumed under this guarantee is limited to the replacement of parts which, by our examination, are proved to be defective and have not been misused, carelessly handled, defaced or damaged due to incorrect installation. This guarantee is VOID where the unit has been opened, tampered with or if repairs have been made or attempted by anyone except an authorised representative of the manufacturing company.

Products for attention under guarantee (unless otherwise agreed) must be returned to the manufacturer freight paid and, if accepted for free repair, will be returned to the customers address in Australia free of charge.

When returning the product for service or repair a full description of the fault and the mode of operation used when the product failed must be given. In any event the manufacturer has no other obligation or liability beyond replacement or repair of this product.

Modifications may be made to any existing or future models of the unit as it may deem necessary without incurring any obligation to incorporate such modifications in units previously sold or to which this guarantee may relate.

This document is the property of the instrument manufacturer and may not be reproduced in whole or part without the written consent of the manufacturer.

This product is designed and manufactured in Australia.