

Application Note: Number AN14

Common Panel Meter Setup Problems

General notes

When a person is setting up an instrument a commonly occurring problem is that the functions they wish to alter do not appear on the display. If this happens the likely cause of the problem is the setting of the “special function” (*SPFN*), sometimes called the “remote input function” (*RIIP*). If this is set to “No Program Access” (*NO.Pc*) or “Setpoint Access Only” (*SP.Pc*) then access to functions will either not be allowed, or will be limited. To check the “special function” setting and obtain access to the functions place a wire link between the instruments external input (normally labeled “EXT-IN” on the electrical installation diagram) and ground. This link is sometimes made via a key switch. With the link in position access to the functions is now possible. When the link is removed the access reverts to the “special function” access setting.

When setting up the instrument it is important to note that if the instrument is left in the function mode for too long it will “time out” and revert to normal measuring mode.

Upon power being applied to the instrument a “switch on” or “wake up” display routine takes place. This typically comprises an LED test (*8888*) followed by factory and software version identification messages and finally a “live” reading from the input sensor or test input. This routine is normal and should not be taken as indicating a fault.

Front view of instrument

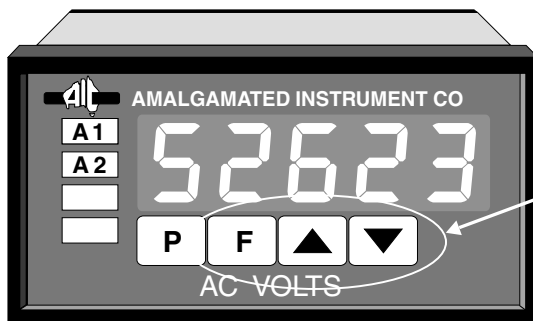

SETUP
PUSH BUTTONS



NOTE: The P push button is used only on certain instruments (refer to instrument manual for instructions)

Rear view of instrument

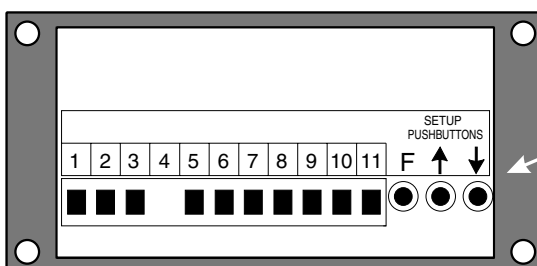

SETUP
PUSH BUTTONS

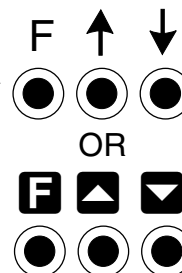

xapsetup-1.0-1

Getting into function (FUNC) mode.

- Instruments with rear panel push buttons

In function mode the operator is able to alter settings such as alarm relay trip points, decimal point settings, display rounding etc. depending on the instrument type. In function mode only you **cannot** change the calibration or scaling points. To get into function mode you must have power applied to the instrument, the display should be showing a “live” reading from the sensor or test input.

1. Press and release the **F** push button.

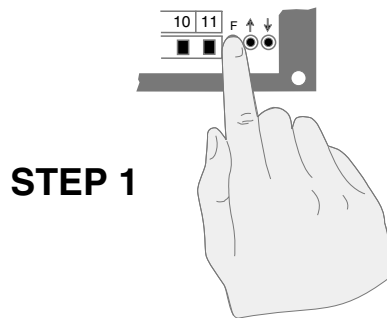

2. Within two seconds of releasing the **F** push button press and release the **▲** and **▼** push buttons together. The display **FUNC** should appear, if not try again from the beginning.



3. Pressing and releasing the **F** push button will allow the operator to step through to the function required.

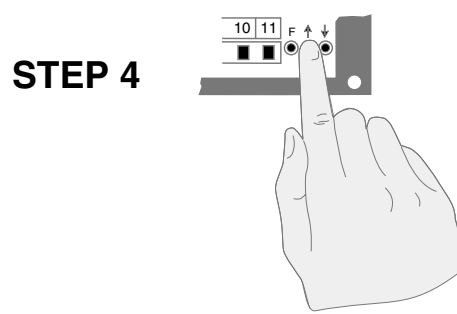
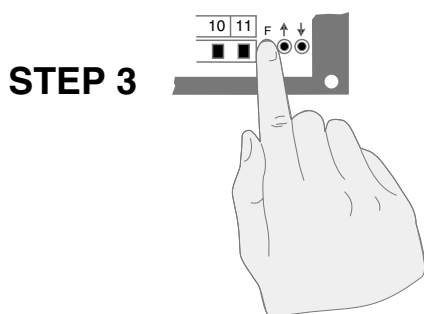

4. When the required function is reached use the **▲** or **▼** push button to change the setting.

Getting into function (FUNC) mode.

- Instruments with front panel push buttons

In function mode the operator is able to alter settings such as alarm relay trip points, decimal point settings, display rounding etc. depending on the instrument type. In function mode only you cannot change the calibration or scaling points. To get into function mode you must have power applied to the instrument, the display should be showing a “live” reading from the sensor or test input.

1. Press and release the **F** push button.

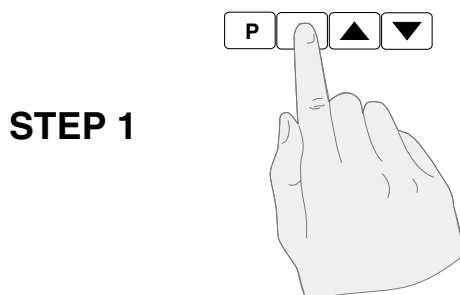

2. Within two seconds of releasing the **F** push button press and release the **▲** and **▼** push buttons together. The display **FUNC** should appear, if not try again from the beginning.

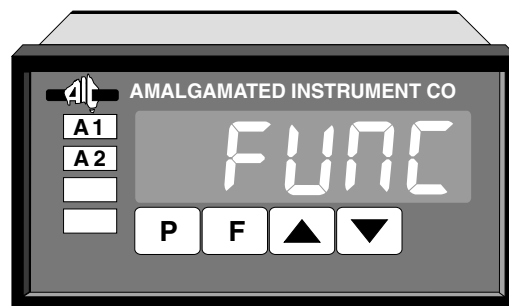
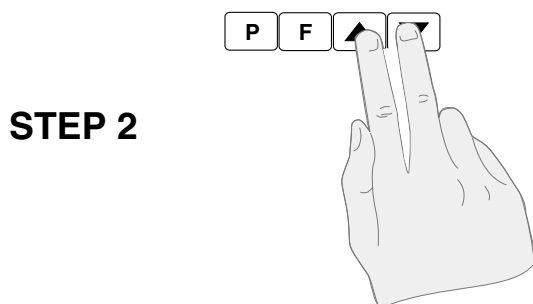

3. Pressing and releasing the **F** push button will allow the operator to step through to the function required.

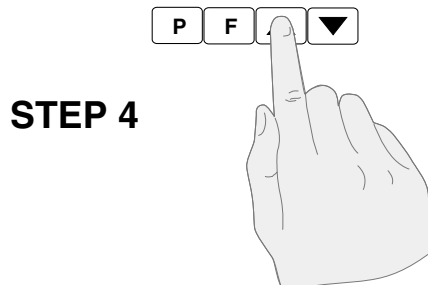
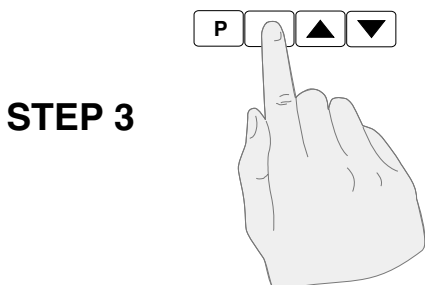

4. When the required function is reached use the **▲** or **▼** push button to change the setting.

Example of changing a function setting

As an example the flow diagram below shows the procedure for changing the digital filter setting from 3 to 6.

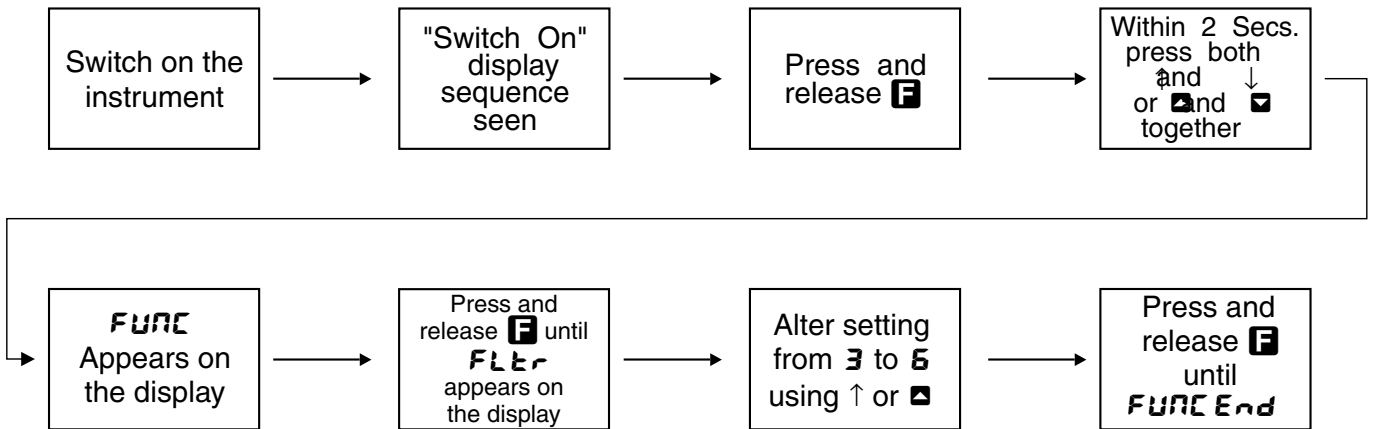

Getting into calibration (CAL) mode

When in calibration mode the operator has access to extra functions including the calibration and scale functions in addition to the functions available in the function mode. Explanations in this section show entering CAL mode and recalibrating the instrument. Recalibration methods will vary between instruments. Generally under the CAL function inputs to the instruments are stored and the value to be displayed for these inputs (the scale (SCL) values) are entered. Typically two points are sampled at the inputs (CAL 1 and CAL 2) and the corresponding scale (display) values (SCL 1 and SCL 2) are set. Ensure that there is a minimum of 10% of input range difference between the two calibration points to avoid calibration error (for greatest accuracy use 0 to 100% of the input range or as near as possible). The description which follows is for a procedure common to many of the PM4 range of instruments.

1. To enter the calibration mode the power must first be turned off, the procedure is then. Hold the **F** push button and switch the instrument on. Keep the **F** push button pressed in until the message **CAL** is observed on the display as part of the “wake up messages”.

The **CAL** display is only present for a short period so watch carefully when power is applied. If the **CAL** display is not seen switch off the power, wait a few seconds, and try again.

Once the **CAL** display is seen the **F** push button can be released. When the switch on messages have finished and a “live” reading from a sensor or test input is present enter the function mode (see the “Getting into function mode” sections) by pressing then releasing the **F** push button and within two seconds pressing **▲** and **▼** together. The display should show **FUNC** for a short time to indicate that function mode is entered. If the **FUNC** message is not seen try again.

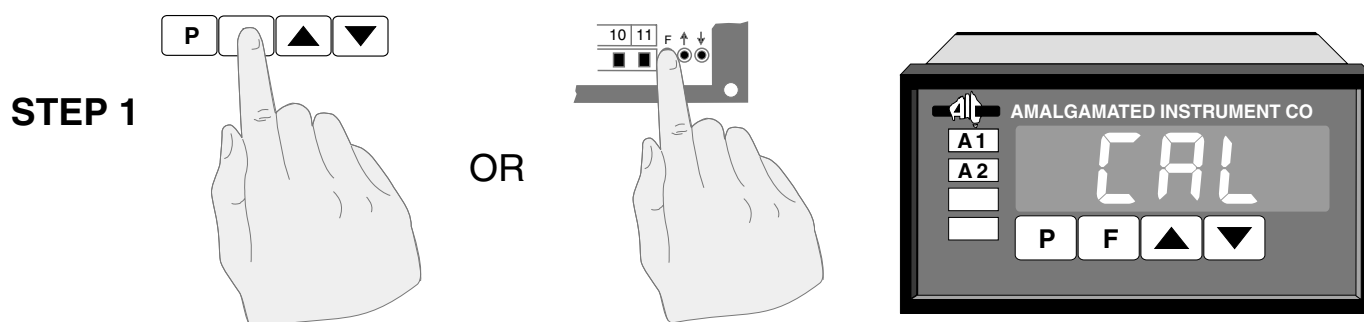

2. Step through the functions by pressing and releasing the **F** push button until the **CAL 1** (or **CAL** in some instruments) display is seen. Press **▲** and **▼** push buttons together, a “live” reading will be displayed.

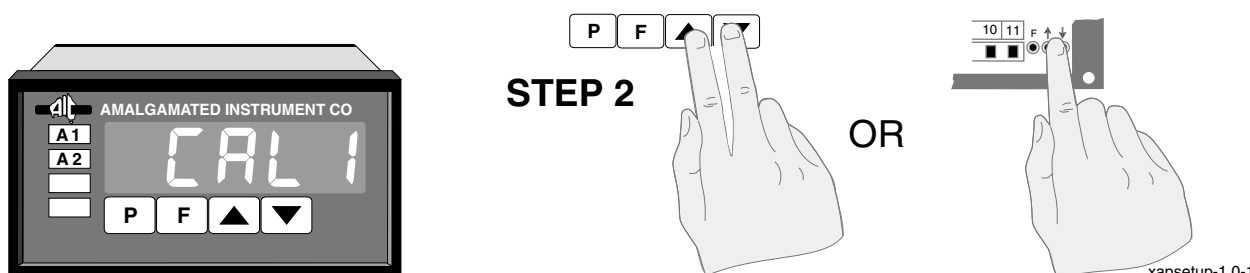

Put the first calibration input into the instrument and check that the reading is stable.

3. Press and release the **F** push button **SCAL 1** will now be displayed and the instrument waits for the operator to input the value to be displayed at the **CAL 1** signal level. The value is changed via the **▲** or **▼** push buttons.

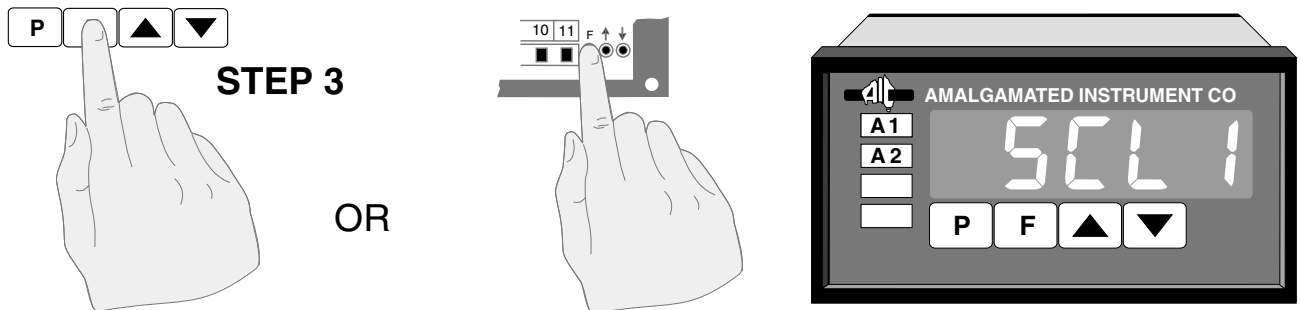

4. When the first scale value is entered press and release the **F** push button, the message **CAL End** may be seen followed by **CAL 2**. Apply the second calibration input signal to the instrument. Remember that the **CAL 2** input must be at least 10% of input range (ideally use 0 & 100% of the input range) different from the **CAL 1** input.

Press **▲** and **▼** together, a “live” reading will be displayed. Follow the same procedure as for **CAL 1** until the second **CAL End** display is seen and the display reverts to normal measuring mode.

An important point to remember when completing a calibration is that the unit remains in calibration mode until power is removed. To reduce the possibility of alteration of calibration and scale settings it is recommended that, following a calibration setup, the power to the instrument should be switched off and on again and the instrument be left to power up normally.

Example of changing calibration and scale settings

The flow diagram below illustrates the procedure for changing the calibration and scale (**CAL 1**, **CAL 2**, **SCL 1** & **SCL 2**) settings. In the example the settings were, for an input of 0V the display reading was **0**, for an input of 5V the display reading was **100**. The new settings required are, for an input of 2V the display reading is **50** and for an input of 10V the display reading is **500**.

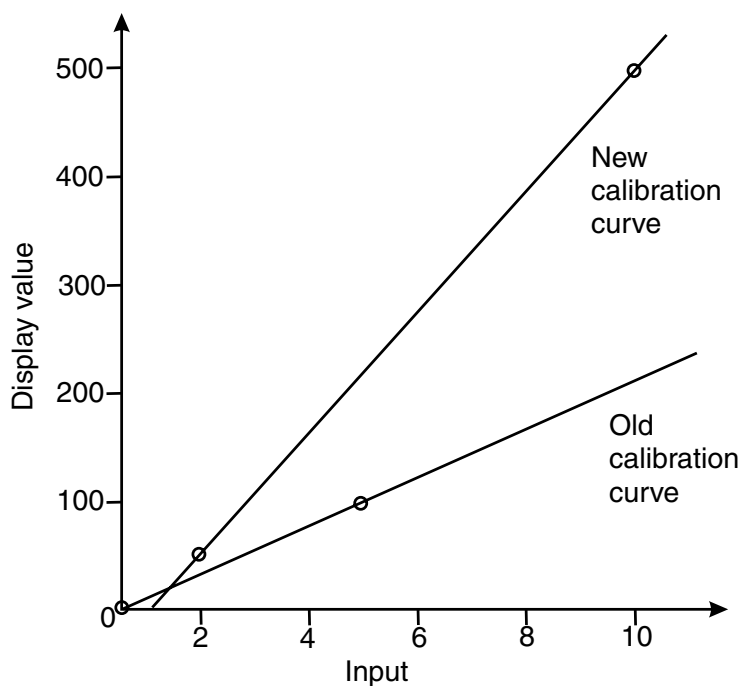
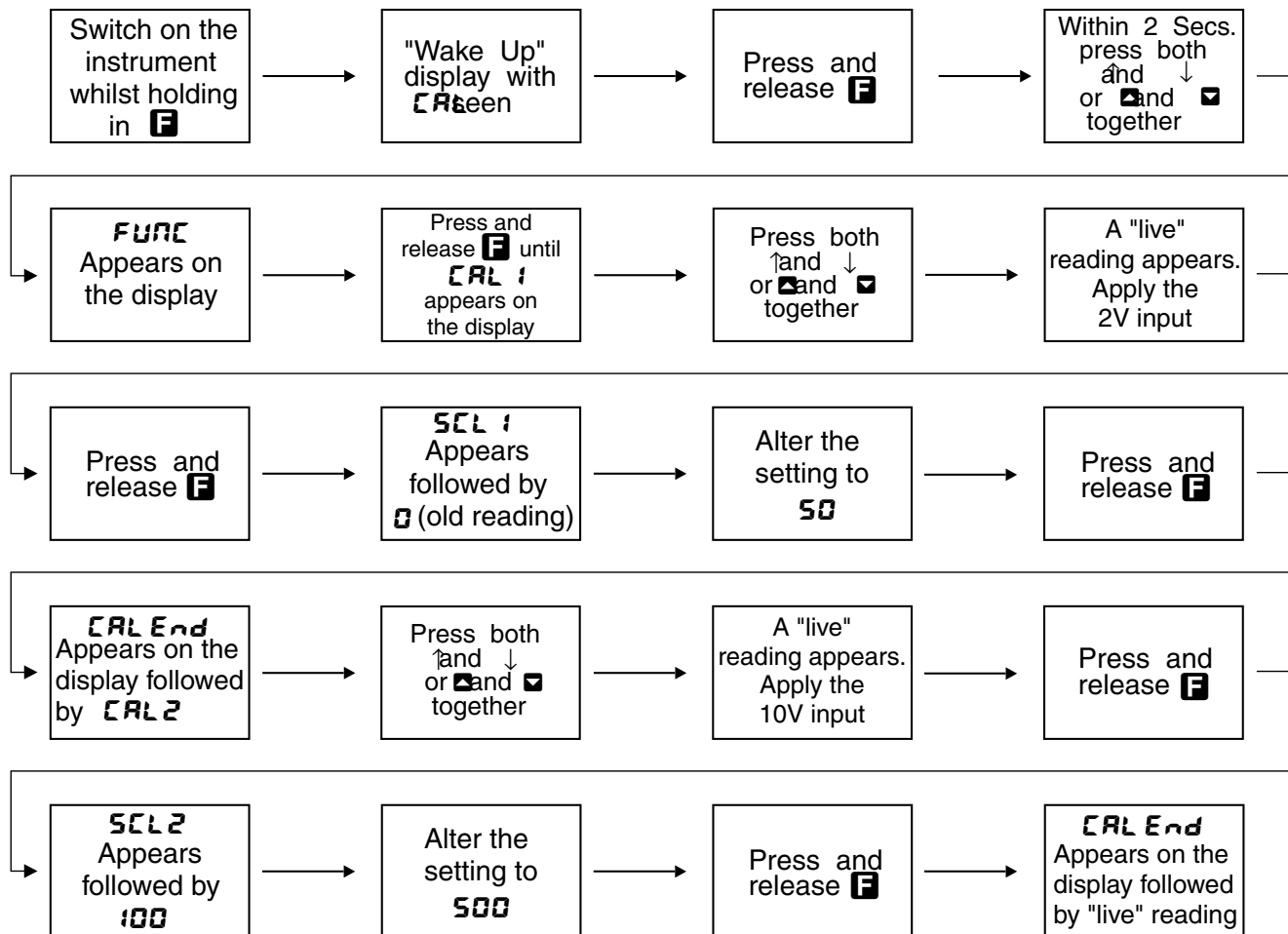

Trouble shooting

This section deals with commonly encountered problems in obtaining full instrument operation.

Display Error Messages

Some errors are identified by the instrument and an error display generated these are:

“**0000**” or “**-or-**” display is indicating that the end of the display range has been reached i.e. the number is too large to be displayed e.g. a display of **10000** is not possible on a 4 digit display. Check the calibration and function settings, if these are OK check that the sensor input is within the range of the calibration settings when this display occurs.

Flashing “**- - - -**” displayed indicates that the input is over range i.e. the input level is too high. Check the sensor connections and that the input from the sensor is within the selected input range.

COP followed by **FR! L** displayed followed by the “switch on” display sequence. This indicates that an internal fault has been generated by the microprocessor in your instrument. A common cause for this is spikes from the power supply, check the supply for spikes and short term drop out. Check or add filtering to the supply. Also check that the instrument case and input leads are correctly earthed.

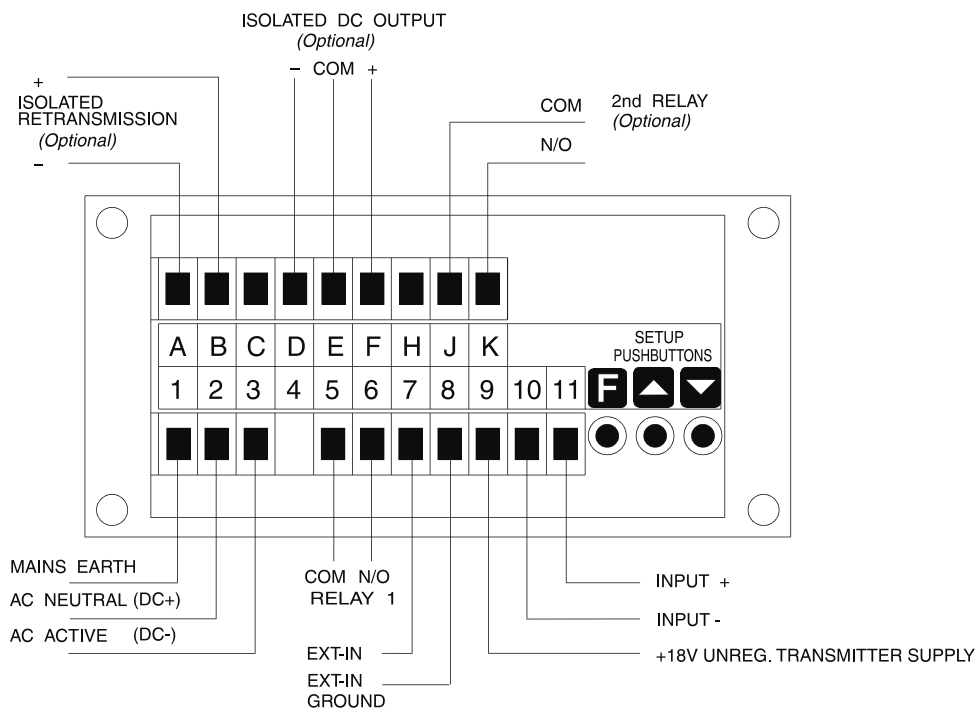

PM4-IV Rear Panel (example)

Calibration and Function Setting Problems

When calibrating the instrument the user must know the input signal range over which the instrument is to operate and the display values required at the calibration points. Read the “Getting into calibration (CAL) mode” section for instructions on entering calibration values. Equally important in obtaining satisfactory operation of an instrument are the setting of the following functions.

Note: Functions available and calibration methods vary between instrument types.

Digital Filter (FLTR) - The digital filter helps to filter noise on the input signal via a weighted averaging software routine. The filter value ranges from 0 (no filter) upwards (typically to 8). As the filter value increases the display response time also increases, therefore it is recommended that the filter value be set at the lowest value needed to stop noise interference. A typical setting is 3.

Decimal Point Selection (dCPL) - The decimal point selection is variable from 1 to 3 decimal point places. If an over range value is being indicated (display showing “ ” or “-or-”) then this may, in some cases be fixed, by reducing the number of decimal point places i.e. **100.00** cannot be displayed on a 4 digit instrument but **100.0** can.

Display Rounding (dRND) - The display rounding allows the display to be set to display only in multiples if required, thus if the display rounding is set to 50 a change in the range 1 to 49 will not be displayed. This is often seen as a fault by the user who knows that the input value is changing but can see no corresponding display change. The display rounding can be set from 0 to 5000 displayed units e.g. an instrument with a decimal point setting of 2 decimal point places can have a display rounding set from 00.00 to 50.00 with intervals of 00.01.

Special Function (SPFN) (or Remote Input R.I.NP) -The special function allows the display of the set function when a link (typically via a switch) is made between the “EXT-IN” rear connection and ground. As seen in Figure 1 the EXT-IN connection is on pin 7 and the ground is on pin 8, note that this applied to the PM4-IV and may not be the same on other instruments. Check the instrument manual for actual pin numbers. If the switch is closed the special function will be in operation, this can be seen as a fault as the normal reading is not taking place. Check the special function setting and switch/link condition if this is proving to be a problem. See the “General notes” section on the first page for comments on the access limitations possible via the special function.

Alarms - If problems are experienced with the alarm operation checks should be made on the “alarm low” and “alarm high” setpoint values. Either setpoint may be set to **OFF** if required by pressing **▲** and **▼** together at the required alarm function display. Associated with these values are the “alarm trip times”, the “normally open/normally closed” settings and, on some instruments the “hysteresis” setting.

The “alarm low” setpoint sets the low display value at which the selected alarm will trip. The “alarm high” setpoint sets the high display value at which the selected alarm will trip. For example if Alarm 1 is set for a low alarm setpoint (**A: L0**) of 12 and a high alarm setpoint (**A: H0**) of 200 the alarm will trip (changeover from its selected normally open (**A: N.O**) or normally closed (**A: N.C**) condition) if the display value either falls below 12 or rises above 200. If these settings are found to be correct then check the “alarm trip time” (**A: TT**), this sets the delay before the alarm will trip (for both low and high alarms). Some instruments have a “hysteresis” or “deadband” function, the hysteresis value being the difference between the alarm switch on and switch off values, once set the hysteresis value is common for both high and low alarm values for the selected alarm. For example we could modify our original alarm operation by specifying an Alarm 1 hysteresis (**A: HY**) value of 4. In this case the low alarm would now trip at a value of 12 but would not reset until a value of 16 (12 + 4) was reached. Similarly the high alarm would trip at 200 but would not reset until the value fell to 196 (200 - 4). If the operator is not aware of the trip times and hysteresis setting it could appear that the alarms are not functioning correctly.

Other function and calibration settings include, setting range limits, input frequency selection, input type selection, bargraph settings etc. Refer to the instrument manual for a full description of function and calibration settings. If problems have arisen in altering the function and calibration values remember that the uncalibration (**UCAL**) function is available to reset the instrument to its factory calibration settings.

Input/Output Selection

Some instruments allow a selection of input/output range or type settings either via link settings or via program control. Check to see that the settings satisfy the input required and the output needed. For example a thermocouple instrument may have been set to expect a Type T input when a Type J thermocouple is actually being used. Check the input/output requirements against the actual instrument setup. Required retransmission output may be 4 - 20mA when the output board is actually set to 0 - 10Volts. See the instruction manual for set up details.

Noise Problems

Noise can introduce itself in forms such as, noise on the power supply line, noise from the input sensor or lead and radiated noise picked up by the instrument. Whilst great care has been taken in the design of the instrument to minimise the effect of noise it is not always possible to eliminate it completely. The presence of noise may show itself in an instrument in a variety of ways, a “rolling” display which appears unstable or a display which frequently resets itself are two common signs. If possible it is best to remove or reduce the source of the noise rather than to try to rectify its effects.

For input noise the digital filter (if available on your instrument) may help to reduce the effect of noise on the instrument, check and alter the setting if needed. Also check instrument and sensor earthing, use shielded cable where possible and site the sensor as far away from the noise source as possible. It is also possible that the sensor itself is generating noise.

Persistent power supply noise may require an external filter to be fitted, or an uprated power supply to be used. An isolating transformer can also help with supply mains interference but should not be fitted without expert advice.

Radiated electromagnetic noise occurs from a wide range of sources some of the most common being: TV and computer monitors, fluorescent light fittings, electrically operated machines such as drills and other machine tools, nearby high power lines or radio transmitters. The further away the instrument is from the noise generator the less the interfering effect will be. To reduce radiated noise interference great care should be taken of earthing (of both chassis and input leads). Any length of input wire left unscreened will act as an aerial, picking up the unwanted radiated noise. If needed, screening, additional to the instrument housing, can be placed around the instrument.

Getting additional help

If problems with instrument operation persist after consulting the instrument manual and these notes you should contact the supplier of the instrument for additional technical help. When you do contact the supplier it would be helpful, and may speed up the process, if certain details are passed on at the time of contact. The table below should be completed as far as possible to assist you in ensuring that the useful information as is passed on. By the heading “switch on” display messages please record the sequence of displays which follow switch on of the instrument.

Returning an instrument

If returning an instrument to the supplier for repair/modification please include the details requested in the table below with the instrument. Also include the delivery address and contact name/department to which the instrument is to be returned.

Details requested	
Full instrument part number: e.g. PM4-IV-240-4E-R	
Serial number:	
Date of purchase:	
Purchased from:	
“Switch on” display messages:	
Details of input sensor used including type, output limits, connection details	
Details of operating environment e.g. used inside a power station	
Description of fault condition	