

# PM5 Panel Meter Optional Output Addendum

---

*AMALGAMATED INSTRUMENT CO*

*Unit 5, 28 Leighton Place Hornsby  
NSW 2077 Australia*

*Telephone: +61 2 9476 2244  
Facsimile: +61 2 9476 2902*

*ABN: 80 619 963 692*

*e-mail: [sales@aicpl.com.au](mailto:sales@aicpl.com.au)  
Internet: [www.aicpl.com.au](http://www.aicpl.com.au)*

# Table of Contents

1	Introduction	3
2	Analog, dual analog outputs plus relay option (-I, -A, -II, -AA -IR, -AR, -IIR and -AAR options)	4
3	Transmitter supply option (-I2, -R12, -I12, -A12, IR12 and -AR12 options)	5
4	One or three relay output option (-R, and -RRR options)	7
5	Three or six relay and analog output option (-R6 and -IR6, AR6, IRRR and ARRR options)	9
6	Serial and 4-20mA output option (-I2, -A2, -I2R, -A2R, -I4, -A4, -I4R and -A4R options)	10
7	Digital output option (-DP, -DP12, -DPR, -DPR12, -DN, -DN12, -DNR and -DNR12 options)	12
8	Serial and second relay output option (-2, -4, -2R and -4R options)	15
9	Serial plus three or five relay output option (-2R5, -2RRR, -4R5, and -4RRR options)	17
10	Serial communications commands	19
11	Ethernet plus RS232/RS485 plus datalogger	24
12	Analog PI control output	25

# 1 Introduction

This manual addendum contains information on the PM5 optional outputs. This manual is supplied whenever a PM5 panel meter is supplied with an optional output fitted. Refer to the standard manual for the PM5 model purchased for information not covered in this addendum.

Note: Not all options are available on all instruments. Check the instruction manual or brochure for the instrument to be used to see which options are available or contact supplier.

## 1.1 Input Output Configuration

If you need to alter the input or output configuration link settings proceed as follows:

1. Remove the plug in terminals from the rear of the instrument

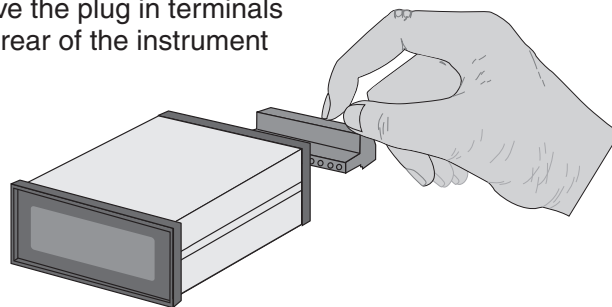

2. Remove the 4 x self tapping screws from the back cover then remove the back cover by pulling it away from the instrument

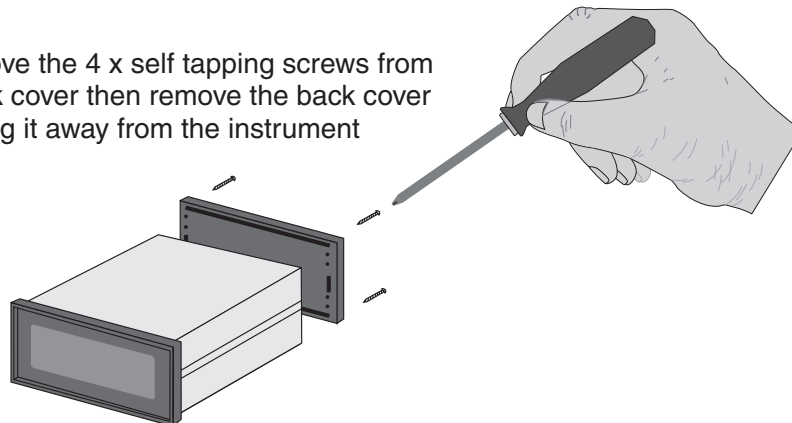

3. Remove the earth screw which passes through the underside of the case then slide out the board or boards

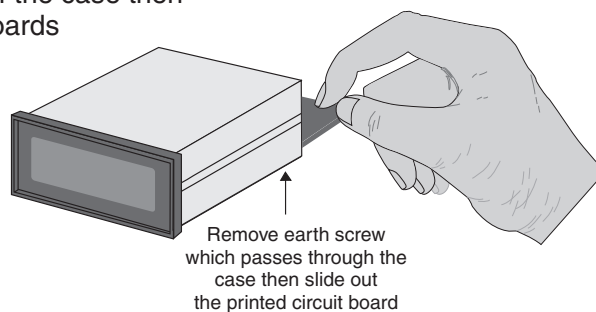

4. Configure the PCB links as required, see appropriate chapter
5. Slide PCB back into case
6. Replace the earth screw which passes through the case
7. Refit the back cover and fix with the self tapping screws
8. Plug the terminal strips back into the rear of the instrument

## 2 Analog, dual analog outputs plus relay option (-I, -A, -II, -AA -IR, -AR, -IIR and -AAR options)

This chapter deals with the the 12 and 16 bit single and dual isolated analog output boards. These boards may also be optionally fitted with a relay. The relay will revert to the normally open (N/O) contact being open when power is removed.

Note: the 12 bit analog output option is 4-20mA output only.

Option code	Options fitted to the board
-I	Single isolated analog output 12 bit 4–20mA only
-A	Single isolated analog output 16 bit 4–20mA, 0–10V (or 12.5 bit 0–1VDC)
-II	Dual isolated analog output 12 bit 4–20mA only
-AA	Dual isolated analog output 16 bit 4–20mA, 0–10V (or 12.5 bit 0–1VDC)
-IR	Single isolated analog output 12 bit 4–20mA only plus relay (form C, rated at 240VAC, 3A into resistive load)
-AR	Single isolated analog output 16 bit 4–20mA, 0–10V (or 12.5 bit 0–1VDC) only plus relay (form C, rated at 240VAC, 3A into resistive load)
-IIR	Dual isolated analog output 12 bit 4–20mA only plus relay (form C, rated at 240VAC, 3A into resistive load)
-AAR	Dual isolated analog output 16 bit 4–20mA, 0–10V (or 12.5 bit 0–1VDC) only plus relay (form C, rated at 240VAC, 3A into resistive load)

### 2.1 Electrical Connections

All electrical connections are at the rear of the instrument. The plug in screw connectors used allow wire of up to 2.5mm<sup>2</sup>. Refer to “Electrical Installation” chapter in the main PM5 manual for general information on electrical connections.

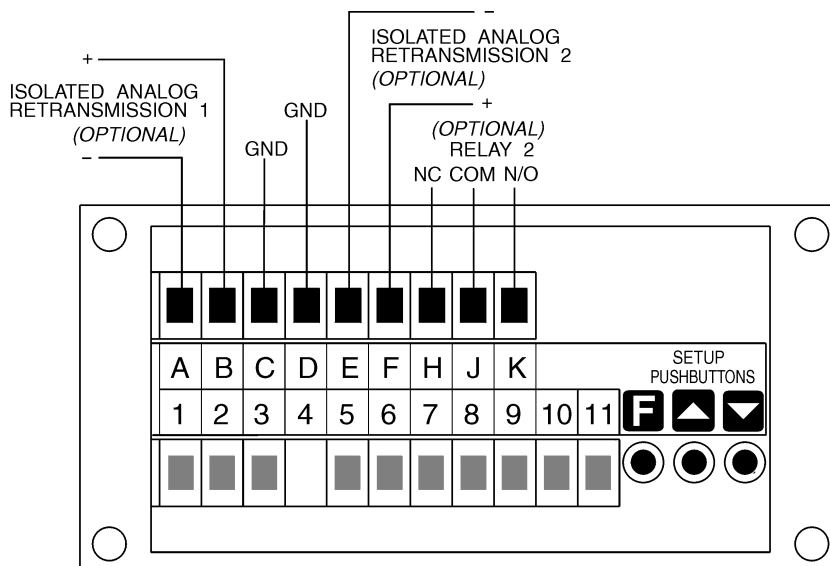

### 3 Transmitter supply option (-12, -R12, -I12, -A12, IR12 and -AR12 options)

This chapter deals with the transmitter supply option circuit board. The transmitter supply may be fitted on its own or with combinations of relay and analog retransmission. The choice between 24VDC ( $\pm 12V$ ) and 10V ( $\pm 5V$ ) is software selectable. The relay will revert to the normally open (N/O) contact being open when power is removed.

Option code	Options fitted to the board
-12	24VDC ( $\pm 12V$ ) or 10V ( $\pm 5V$ ) isolated and regulated transmitter supply rated at 20mA max.
-R12	24VDC ( $\pm 12V$ ) or 10V ( $\pm 5V$ ) isolated and regulated transmitter supply rated at 20mA max. plus extra relay (form C, rated at 240VAC, 3A into resistive load)
-12I	12 bit 4–20mA only analog retransmission plus 24VDC ( $\pm 12V$ ) or 10V ( $\pm 5V$ ) isolated and regulated transmitter supply rated at 20mA max.
-12A	16 bit 4–20mA, 0–10VDC (or 12.5 bit 0–1VDC) analog retransmission plus 24VDC ( $\pm 12V$ ) or 10V ( $\pm 5V$ ) isolated and regulated transmitter supply rated at 20mA max.
-12IR	24VDC ( $\pm 12V$ ) or 10V ( $\pm 5V$ ) isolated and regulated transmitter supply rated at 20mA max. plus 12 bit 4–20mA only analog retransmission plus extra relay (form C, rated at 240VAC, 3A into resistive load)
-12AR	24VDC ( $\pm 12V$ ) or 10V ( $\pm 5V$ ) isolated and regulated transmitter supply rated at 20mA max. plus 16 bit 4–20mA, 0–10VDC (or 12.5 bit 0–1VDC) analog retransmission plus extra relay (form C, rated at 240VAC, 3A into resistive load)

#### 3.1 Electrical Connections

All electrical connections are at the rear of the instrument. The plug in screw connectors used allow for wire of up to 2.5mm<sup>2</sup>. Connect across D and F for 24V/10V or across E and F for 12V/5V or across D and E for -12V/-5V. Refer to “Electrical Installation” chapter in the main PM5 manual for general information on electrical connections.

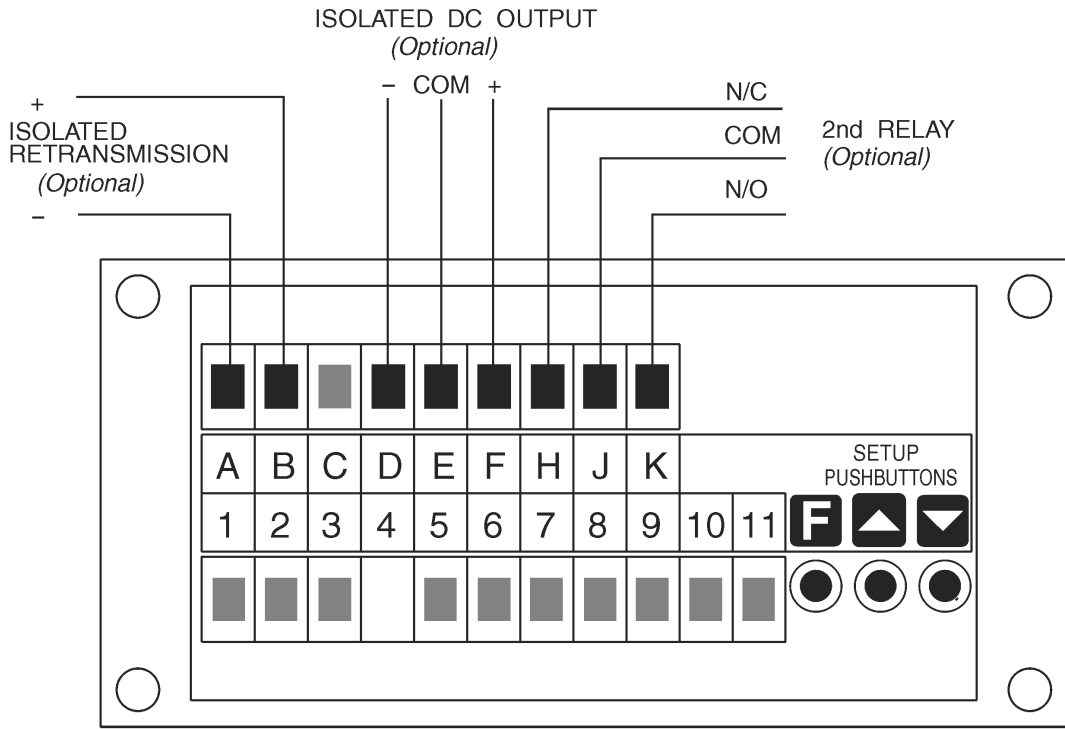

## 4 One or three relay output option (-R, and -RRR options)

This chapter deals with the the one or three extra relay output options.

Option code	Options fitted to the board
-R	Second relay output (form C, rated at 240VAC, 5A into resistive load)
-RRR	Second, third and fourth extra relay output (form C, rated at 240VAC, 5A into resistive load)

All relays will revert to the normally open (N/O) contacts being open circuit when power is removed.

An alternative solid state relay driver output version (switches 24VDC to drive an external solid state relay (not supplied)) is available to order.

### 4.1 Electrical Connections

All electrical connections are at the rear of the instrument. The plug in screw connectors used allow for wire of up to 2.5mm<sup>2</sup>. Refer to “Electrical Installation” chapter in the main PM5 manual for general information on electrical connections.

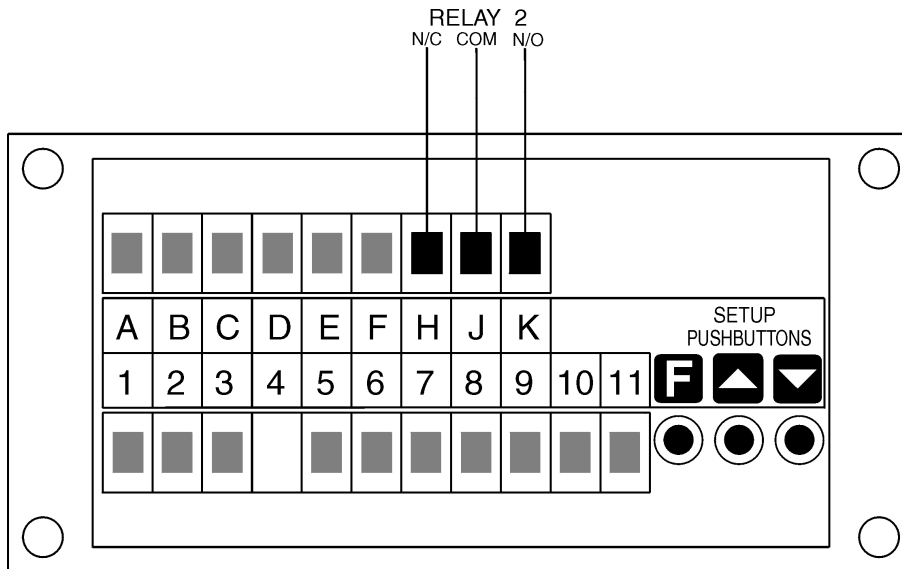

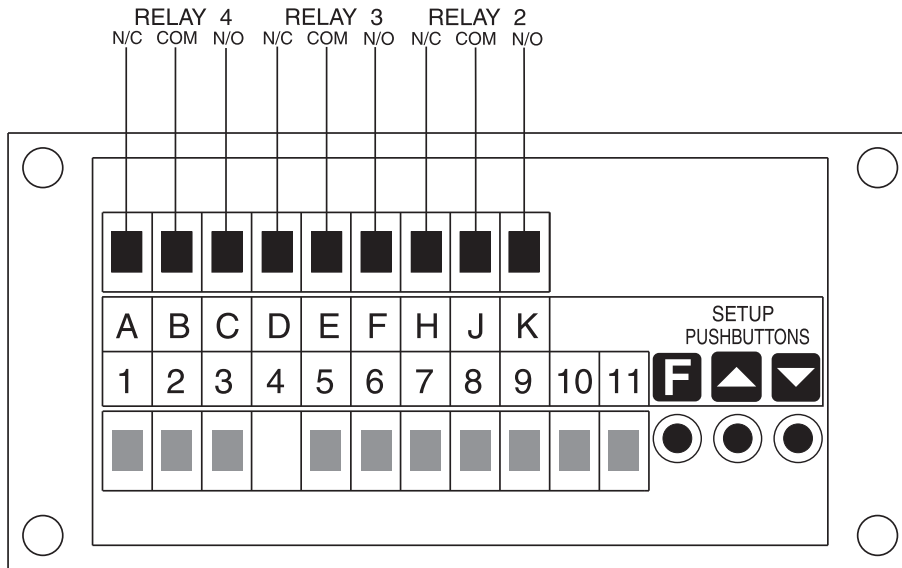



## 5 Three or six relay and analog output option (-R6 and -IR6, AR6, IRRR and ARRR options)

The optional output board is factory supplied with the necessary components for the output options required. The last digits in the model number, which can be found at the bottom of the label on the instrument case, indicate the options fitted, option combinations available with this board are shown in the table below. Relays are form A, rated 240VAC, 1A resistive load. All relays will revert to the normally open (N/O) contacts being open when power is removed.

Option code	Options fitted to the board
-R6	Six extra relays (form A, rated at 240VAC, 2A into resistive load)
-IR6	Six extra relays (form A, rated at 240VAC, 2A into resistive load) plus isolated 12 bit 4–20mA only analog retransmission
-AR6	Six extra relays (form A, rated at 240VAC, 2A into resistive load) plus isolated 16 bit 4–20mA, 0–10VDC (or 12.5 bit 0–1VDC) analog retransmission
-IRRR	Three extra relays (form A, rated at 240VAC, 2A into resistive load) plus isolated 12 bit 4–20mA only analog retransmission
-ARRR	Three extra relays (form A, rated at 240VAC, 2A into resistive load) plus isolated 16 bit 4–20mA, 0–10VDC (or 12.5 bit 0–1VDC) analog retransmission

### 5.1 Electrical Connections

All electrical connections are at the rear of the instrument. The plug in screw connectors used allow for wire of up to 2.5mm<sup>2</sup>. Refer to “Electrical Installation” chapter in the main PM5 manual for general information on electrical connections.

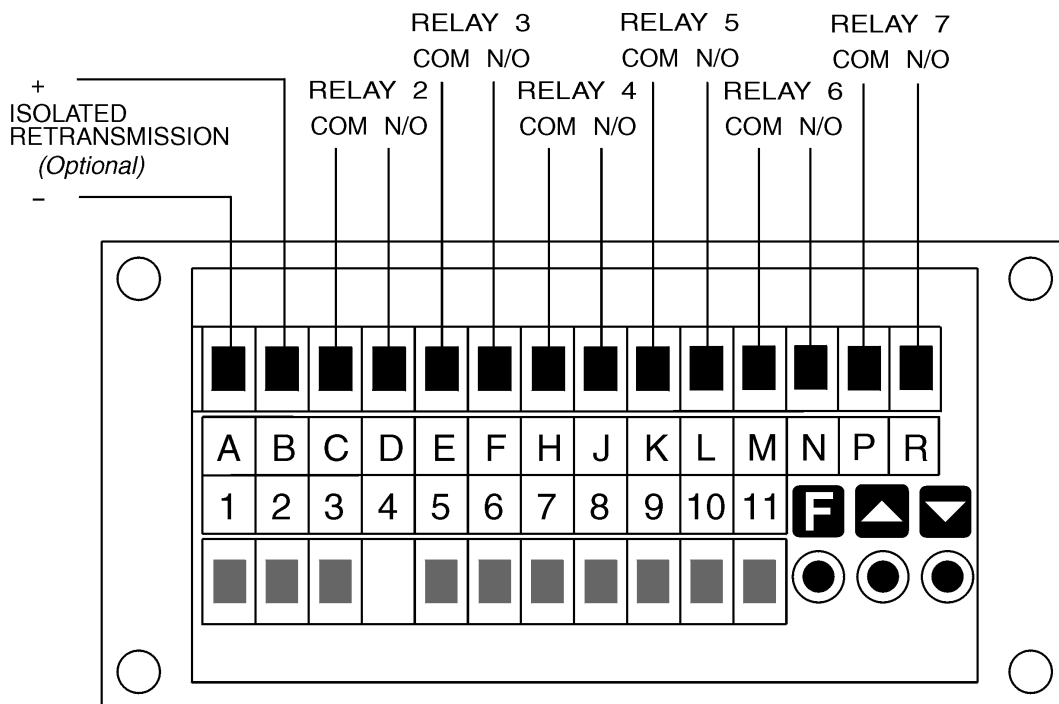

## 6 Serial and 4-20mA output option

### (-I2, -A2, -I2R, -A2R, -I4, -A4, -I4R and -A4R options)

This addendum covers instruments with the isolated serial/isolated analog output board. This board allows output of either RS232 or RS485 plus 4–20mA plus a second relay. The last digits in the model number, which can be found at the bottom of the label on the instrument case, indicate the options fitted, option combinations available with this board are show in the table below. Note: Voltage output is not available with this board. Relays are form C, rated 240VAC, 5A resistive load. The relay will revert to the normally open (N/O) contact being open when power is removed.

Option code	Options fitted to the board
-2I	Isolated RS232 serial communication plus isolated 12 bit 4–20mA only output
-2A	Isolated 16 bit 4–20mA, 0–10VDC (or 12.5 bit 0–1 VDC) output plus isolated RS232 serial communication
-2IR	Isolated RS232 serial communication plus isolated 12 bit 4–20mA only output plus second relay (form C, rated at 240VAC, 3A into resistive load)
-2AR	Isolated RS232 serial communication plus isolated 16 bit 4–20mA, 0–10VDC (or 12.5 bit 0–1 VDC) output plus second relay (form C, rated at 240VAC, 3A into resistive load)
-4I	Isolated RS485 serial communication plus isolated 12 bit 4–20mA only output
-4A	Isolated RS485 serial communication plus isolated 16 bit 4–20mA, 0–10VDC (or 12.5 bit 0–1 VDC) output
-4IR	Isolated RS485 serial communication plus isolated 12 bit 4–20mA only output plus second relay (form C, rated at 240VAC, 3A into resistive load)
-4AR	Isolated RS485 serial communication plus isolated 16 bit 4–20mA, 0–10VDC (or 12.5 bit 0–1 VDC) output plus second relay (form C, rated at 240VAC, 3A into resistive load)

### 6.1 Electrical Connections

All electrical connections are at the rear of the instrument. The plug in screw connectors used allow for wire of up to 2.5mm<sup>2</sup>. Refer to “Electrical Installation” chapter in the main PM5 manual for general information on electrical connections.

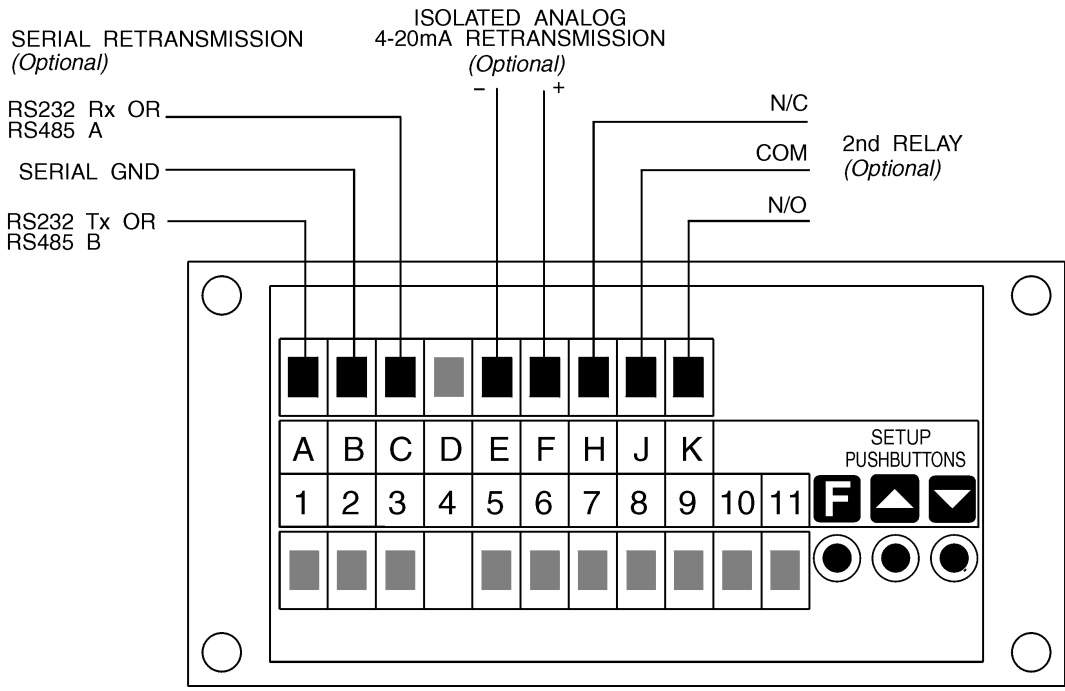

## 7 Digital output option (-DP, -DP12, -DPR, -DPR12, -DN, -DN12, -DNR and -DNR12 options)

This chapter deals with the the isolated digital output option circuit board. The digital output is available in PNP or NPN versions and each may be fitted on its own or with combinations of relay and excitation voltage. The choice of excitation voltage between 24VDC and 5VDC is software selectable. The relay will revert to the normally open (N/O) contact being open when power is removed.

Option code	Options fitted to the board
-DP	16 bit PNP binary or BCD output
-DP12	16 bit PNP binary or BCD output plus DC excitation voltage selectable as 5V (100mA max) or 24V (20mA max)
-DPR	16 bit PNP binary or BCD output plus extra relay (form A, 3A @ 240VAC)
-DP12R	16 bit PNP binary or BCD output plus DC excitation voltage selectable as 5V (100mA max) or 24V (20mA max) plus extra relay (form A, 3A @ 240VAC)
-DN	16 bit NPN binary or BCD output
-DN12	16 bit NPN binary or BCD output plus DC excitation voltage selectable as 5V (100mA max) or 24V (20mA max)
-DNR	16 bit NPN binary or BCD output plus extra relay (form A, 3A @ 240VAC)
-DN12R	16 bit NPN binary or BCD output plus DC excitation voltage selectable as 5V (100mA max) or 24V (20mA max) plus extra relay (form A, 3A @ 240VAC)

### 7.1 Electrical Connections

All electrical connections are at the rear of the instrument. Refer to “Electrical Installation” chapter in the main PM5 manual for general information on electrical connections.

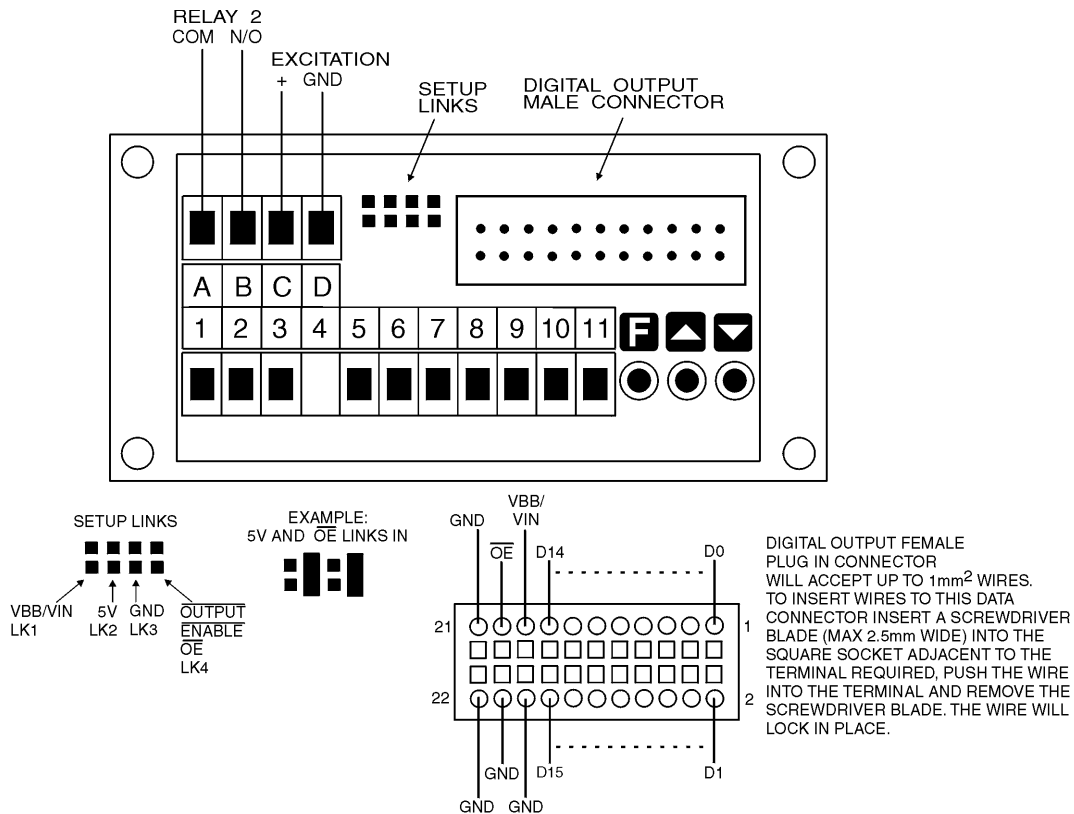

## 7.2 PNP output connections

All selection links are located at the rear of the instrument. The PNP output requires an external voltage VBB at terminal 17 (48VDC maximum).

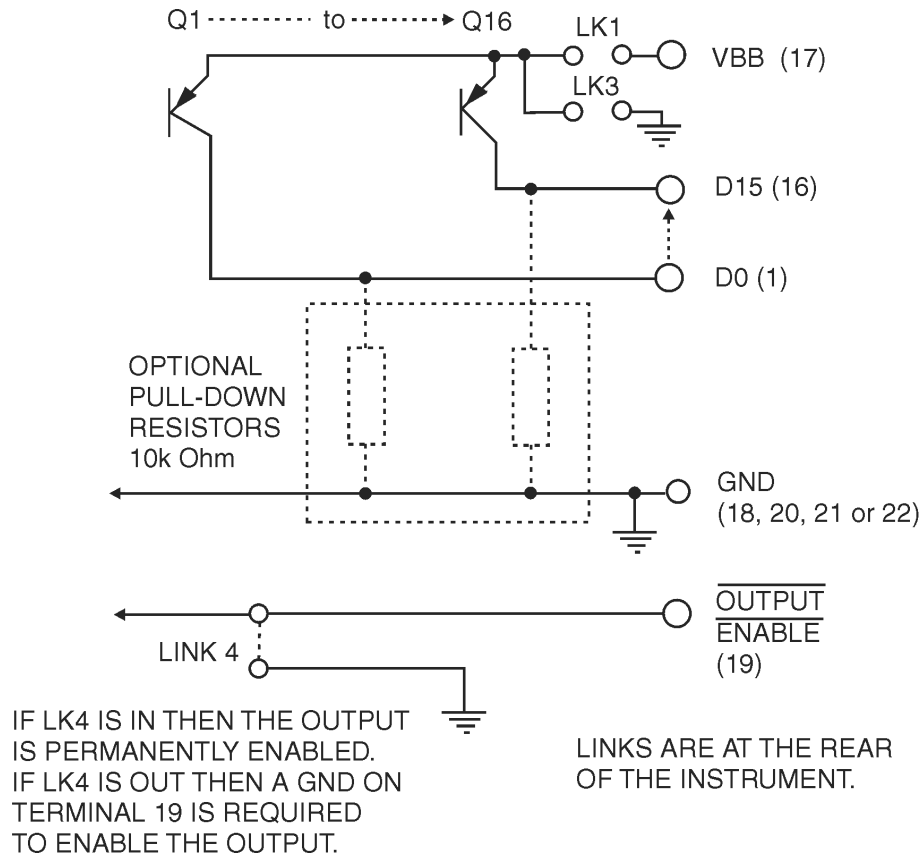

### 7.3 NPN output connections

All selection links are located at the rear of the instrument. If no voltage is available at the signal input of the receiving device then optional pull up resistors can be fitted and the voltage supplied from 5V internally (via LK2) or via an externally applied voltage VIN at terminal 17 (via LK1, 48VDC maximum).

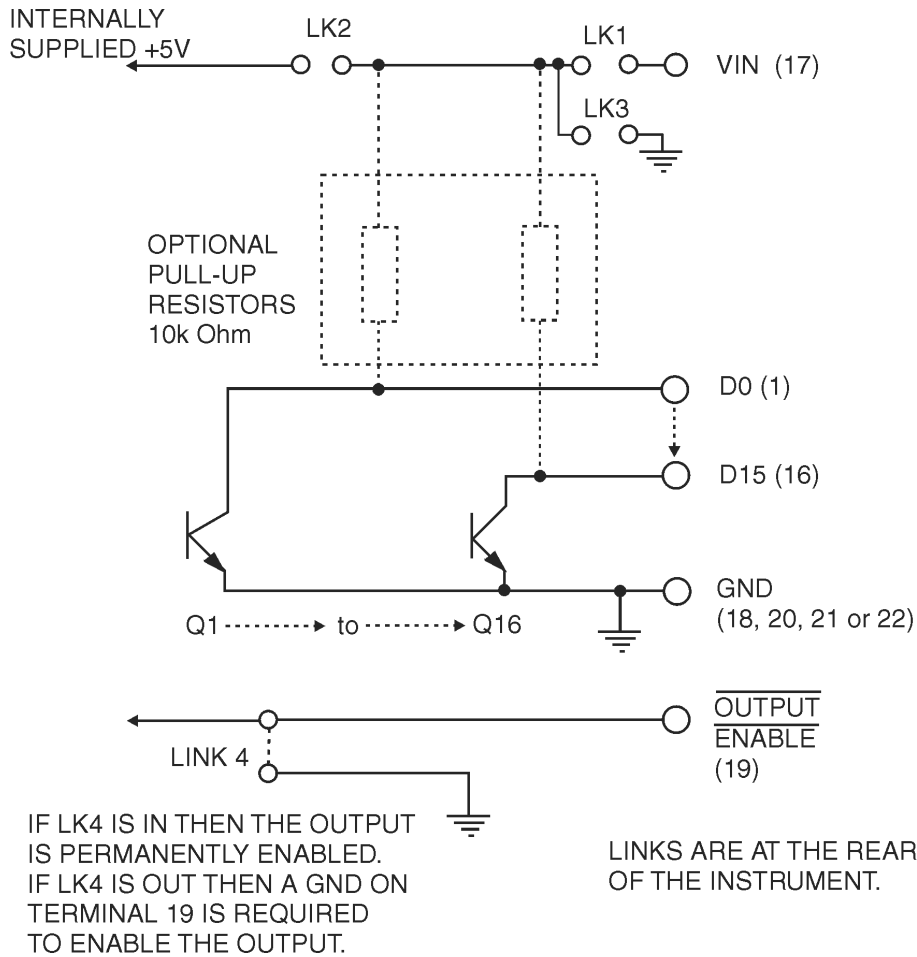

## 8 Serial and second relay output option (-2, -4, -2R and -4R options)

The information provided in this section relates to PM5 panel meters with isolated RS232 or isolated RS485 outputs using the optional serial output board. The relay is form A, rated 240VAC, 5A resistive load. The relay will revert to the normally open (N/O) contact being open when power is removed.

Option code	Options fitted to the board
-2	Isolated RS232 serial communication
-4	Isolated RS485 serial communication
-2R	Isolated RS232 serial communication and second relay (form C, rated at 240VAC, 3A into resistive load)
-4R	Isolated RS485 serial communication and second relay (form C, rated at 240VAC, 3A into resistive load)

### 8.1 Electrical Connections

All electrical connections are at the rear of the instrument. The plug in screw connectors used allow for wire of up to 2.5mm<sup>2</sup>. Refer to “Electrical Installation” chapter in the main PM5 manual for general information on electrical connections.

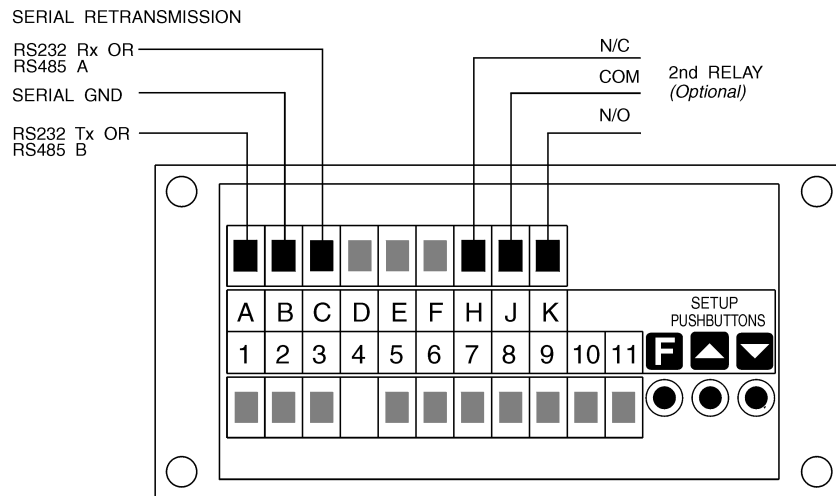

## 8.2 System interconnections - RS232 Communications

Use 3 core shielded cable for RS232 connections. RS232 connections generally have Rx at the PM5 connected to Tx at the PLC/Computer etc. and Tx at the PM5 connected to Rx at the PLC/Computer etc. RS232 connections are usually rated to a maximum cable length of approximately 15 metres and are single ended in operation i.e. only one device can be connected to the PM5. An RS232 to RS485 converter may be used to increase the cable length and number of unit connections.

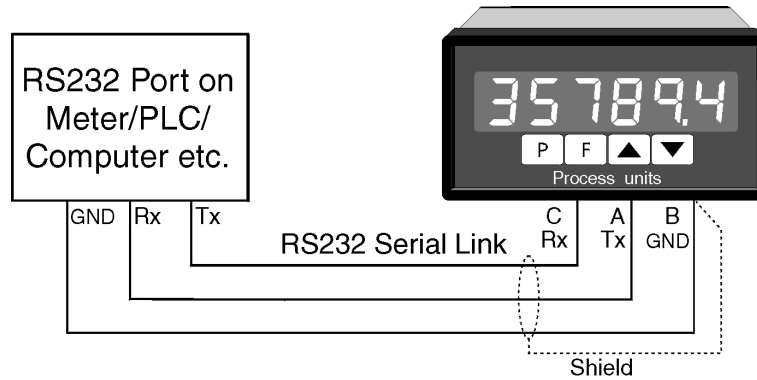

## 8.3 System interconnections - RS485 Connections

RS485 connections use shielded, twisted pair wires. RS485 is rated to a maximum cable length of approximately 1200 metres and will allow connection of up to 32 terminals on the serial link.

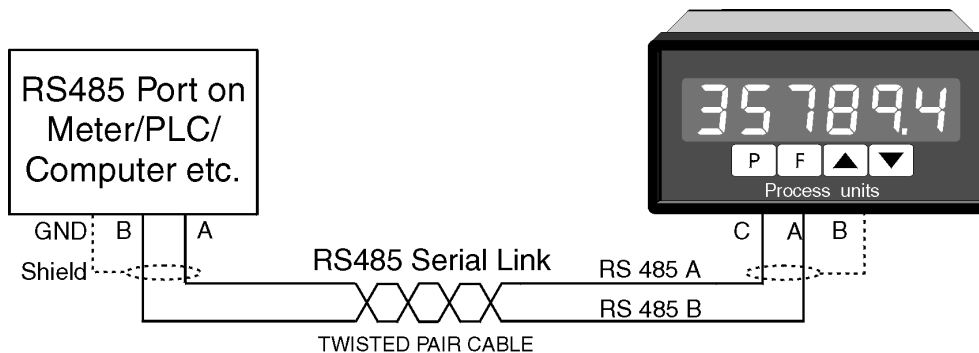



## 9 Serial plus three or five relay output option (-2R5, -2RRR, -4R5, and -4RRR options)

This chapter deals with the the serial plus three or five extra relay output options.

Option code	Options fitted to the board
-2R5	RS232 and 5 extra relay output (form A, rated at 240VAC, 2A into resistive load)
-2RRR	RS232 and 3 extra relay output (form A, rated at 240VAC, 2A into resistive load)
-4R5	RS485 and 5 extra relay output (form A, rated at 240VAC, 2A into resistive load)
-4RRR	RS485 and 3 extra relay output (form A, rated at 240VAC, 2A into resistive load)

All relays will revert to the normally open (N/O) contacts being open circuit when power is removed.

### 9.1 Electrical Connections

All electrical connections are at the rear of the instrument. The plug in screw connectors used allow for wire of up to 2.5mm<sup>2</sup>. Refer to “Electrical Installation” chapter in the main PM5 manual for general information on electrical connections.

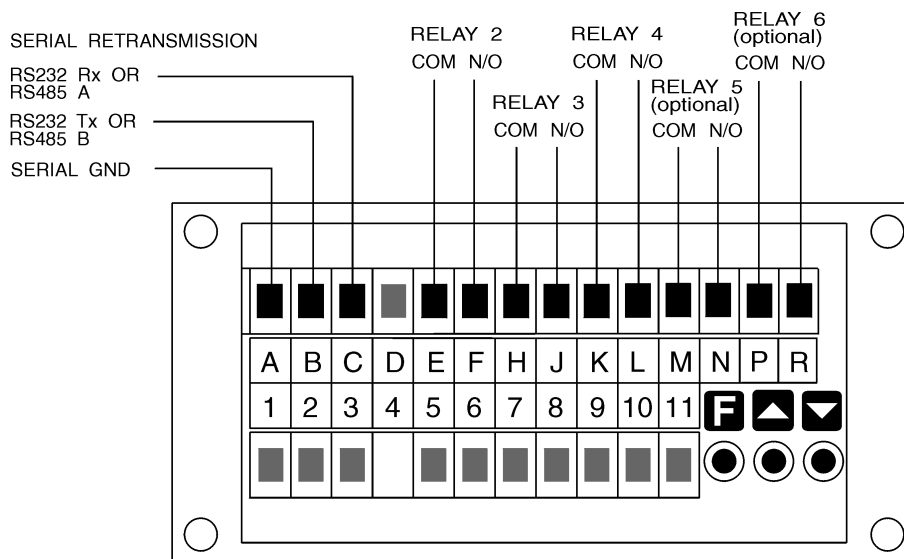

## 9.2 System interconnections - RS232 Communications

Use 3 core shielded cable for RS232 connections. RS232 connections generally have Rx at the PM5 connected to Tx at the PLC/Computer etc. and Tx at the PM5 connected to Rx at the PLC/Computer etc. RS232 connections are usually rated to a maximum cable length of approximately 15 metres and are single ended in operation i.e. only one device can be connected to the PM5. An RS232 to RS485 converter may be used to increase the cable length and number of unit connections.

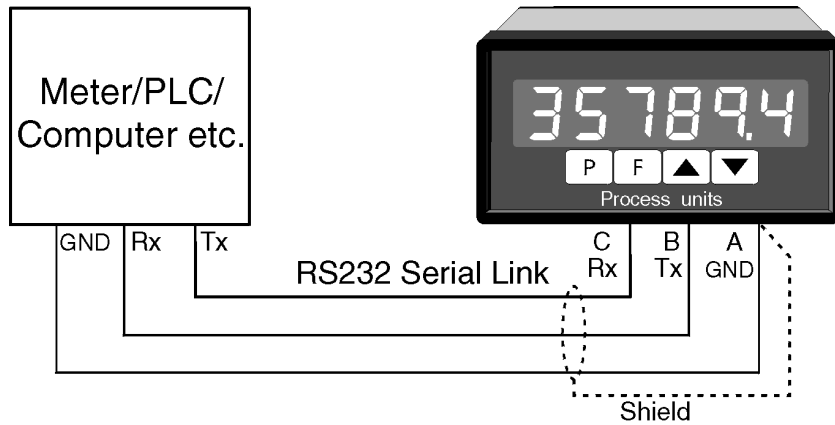

## 9.3 System interconnections - RS485 Connections

RS485 connections use shielded, twisted pair wires. RS485 is rated to a maximum cable length of approximately 1200 metres and will allow connection of up to 32 terminals on the serial link.

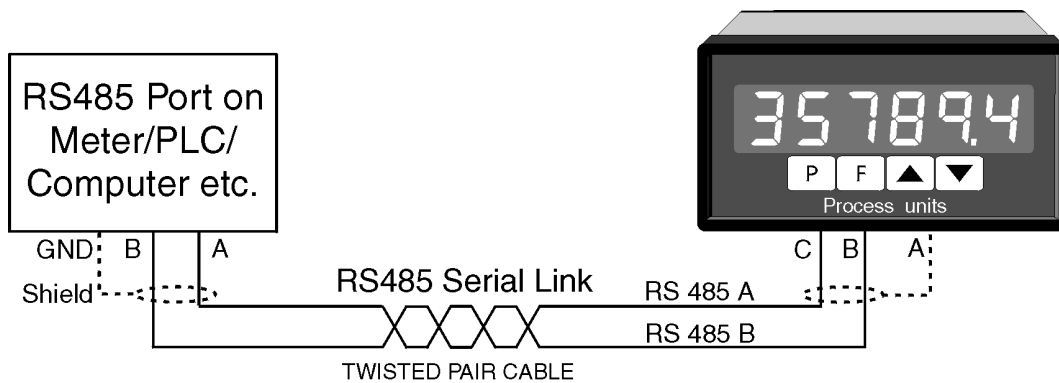

# 10 Serial communications commands

## 10.1 Cont - Continuous output mode

In this mode the display value is continually sent via the RS232/485 interface in ASCII format with 8 data bits + 1 stop bit. Data will be updated at slightly less than the sample rate for the instrument being used. The standard format for **Cont** mode is as follows:-

<STX>XYYYY<CR>

- Where
- <STX> is the ASCII Start of text character (2 Dec., 02 Hex.)
  - X is an ASCII Space character (32 Dec., 20 Hex.) for a positive value or
  - X is the ASCII character “-” (45 Dec., 2D Hex) for a negative value  
note on some instruments depending on the mode the space character may not be transmitted
  - YYYY is the display value in ASCII (number of digits depends on number of display digits  
e.g. 4 digits plus decimal point, if used, for a 4 digit display)
  - <CR> is the ASCII Carriage return character (13 Dec., 0D Hex.)

e.g.: If the display is showing 123456 then the instrument will send 02 31 32 33 34 35 36 0D (HEX) to the host. The table below shows the outputs for instruments with more than one possible display value.

Model	Continuous output Note decimal points will also be sent if displayed. Note in some modes in certain instruments leading spaces (X in the strings below) may not be transmitted
PM5-CO	<STX>VVVVVV,WWWWWW,XYYYYYY,XZZZZZZ<CR> where: VVVVVV is the channel 1 value (up to 6 characters/spaces) “,” is a comma (44 dec, 2C hex) X is a space for positive value or “-” sign WWWWWW is the channel 2 value (up to 6 characters/spaces) YYYYYY is the temperature 1 value (up to 6 characters/spaces) ZZZZZZ is the temperature 2 value (up to 6 characters/spaces)
PM5-RS	<STX>XZZZZZZ<CR> where: X is a space for positive value or “-” sign ZZZZZZ is the temperature value (up to 8 characters/spaces) In <b>RSER</b> mode the wind speed will be transmitted first followed by a comma then the direction e.g. <STX>XSSSS,XDDDD<CR>.
PM5-TR	<STX>VVVVV,XWWWWW,XYYYYY<CR> where: VVVVVV is the rate value (number of digits depends on display type) “,” is a comma (44 dec, 2C hex) X is a space for positive value or “-” sign XWWWWW is the total value YYYYYY is the grand total value
PM5-TMR	<STX>XZZZZZZ<CR> where: X is a space for positive value or “-” sign ZZZZZZ is the time (up to 6 characters/spaces) decimal points and colons can additionally be displayed e.g. 1:25:15.2 for hours, mins and secs with 1 decimal place

## 10.2 **POLL** - Host Controlled Transmit Mode

This mode requires a host computer or PLC to poll the instrument to obtain display or other information or reset various setpoint parameters. Terminal communications software is required when using **POLL** mode with a PC. Data is in ASCII format with 8 data bits + 1 stop bit. Addresses are offset by 32 Dec. i.e. address 1 is 33 Dec. When polling the instrument it is essential that the command characters are sent with less than a 10mS delay between them. This normally means that each command line must be sent as a whole string e.g. <STX>PA<CR> is sent as one string rather than <STX> on one line followed by P etc. If testing using at terminal program this is normally achieved by allocating a command string to a function key. Whenever the function key is operated the whole string is sent. The format used is ASCII (8 data bits + 1 stop bit) so, for instance, if address 1 is used then the string <STX>PA<CR> must be put into the terminal program as:

^BP!^M

where: ^B is the ASCII character for STX  
P is the command line to transmit the primary display value  
! is the ASCII character for address 1 (33 Dec of 21 Hex)  
^M is the ASCII character for CR

A typical format for the host command is as follows:-

<STX>CA<CR> (Standard read etc.)  
<STX>CA<CR>N<CR>XYYYY (Set Value Command)

Where: <STX> is Start of Text Character (2 Dec, 02 Hex, ^B ASCII)  
C is the command character (see following commands)  
A is the unit address (Range: 32 to 63 Dec, 20 to 3F Hex, "SPACE" to ? ASCII the address is offset by 32 Dec, 20 Hex)  
<CR> is Carriage Return (13 Dec, 0D Hex, ^M ASCII)  
N is the setpoint number in ASCII  
e.g.: 1 for alarm 1 etc.  
X SPACE for positive and "-" for negative  
YYYY is the setpoint value in ASCII

The **POLL** commands available and instrument responses are as follows:

### 1. Transmit Primary Display Value: <STX>PA<CR>

e.g. ^BP!^M using a terminal program (address 1). Instructs unit to return the primary display value. The primary value is the main reading.

Format of returned data is:

<ACK>PAXYYYY<CR>

Where: <ACK> is Acknowledge (6 Dec, 06 Hex)  
P echo command received "P" (80 Dec, 50 Hex)  
A is the responding units address  
X SPACE for positive and "-" for negative  
YYYY is the display value in ASCII  
<CR> is a Carriage Return (13 Dec, 0D Hex)

The number of display characters returned depends on the number of display digits present. If the decimal point is non zero then it will be sent in the appropriate place as "." (46 Dec, 2E Hex). The primary display for most instruments is the main reading, in some instruments the main reading

may not be obvious, for those instruments the primary display value is shown in the table below.

Model	Primary display value
PM5-CO	Channel 1 value
PM5-RS	Display value in <b>URL</b> , <b>ASCII</b> , <b>131</b> modes Wind speed in NMEA mode
PM5-TR	Rate value

## 2. Transmit Secondary Display Value: <STX>SA<CR>

e.g. ^BS!^M using a terminal program (address 1). Instructs unit to return the secondary display value. If no secondary display value is used the instrument will return the primary display value. Format of returned data is:

<ACK>SAXYYYY<CR>

Where:

<ACK>	is Acknowledge (6 Dec, 06 Hex)
S	echo command received "S" (83 Dec, 53 Hex)
A	is the responding units address
X	SPACE for positive and "-" for negative
YYYY	is the display value in ASCII
<CR>	is a Carriage Return (13 Dec, 0D Hex)

The number of display characters returned depends on the number of display digits present. If the decimal point is non zero then it will be sent in the appropriate place as "." (46 Dec, 2E Hex). The secondary display value, for instruments using a second display value rather than repeating the primary display value or returning the special function value, is shown in the table below.

Model	Secondary display value
PM5-CO	Channel 2 value
PM5-RS	Wind direction in <b>NMEA</b> mode Not used in other modes
PM5-TR	Total value

## 3. Transmit Tertiary Display Value: <STX>TA<CR>

e.g. ^BT!^M using a terminal program (address 1). Instructs unit to return the tertiary display value. If no tertiary display value is used the instrument will return an invalid command character "?".

Format of returned data is:

<ACK>TAXYYYY<CR>

Where:

<ACK>	is Acknowledge (6 Dec, 06 Hex)
T	is the echo command received "T" (84 Dec, 54 Hex)
A	is the responding units address
X	SPACE for positive and "-" for negative
YYYY	is the display value in ASCII
<CR>	is a Carriage Return (13 Dec, 0D Hex)

The number of display characters returned depends on the number of display digits present. If the decimal point is non zero then it will be sent in the appropriate place as "." (46 Dec, 2E Hex). The tertiary display value, for instruments using a tertiary display value, is shown in the table below.

Model	Tertiary display value
PM5-C0	Temperature 1 value
PM5-RS	Not used
PM5-TR	Grand total value

#### 4. Transmit Quad Display Value: <STX>QA<CR>

e.g. ^BQ!^M using a terminal program (address 1). Instructs unit to return the quad display value. If no quad display value is used the instrument will return an invalid command character “?”.

Format of returned data is:

<ACK>TAXYYYY<CR>

Where:

<ACK>	is Acknowledge (6 Dec, 06 Hex)
Q	is the echo command received “Q” (81 Dec, 51 Hex)
A	is the responding units address
X	SPACE for positive and “-” for negative
YYYY	is the display value in ASCII
<CR>	is a Carriage Return (13 Dec, 0D Hex)

The number of display characters returned depends on the number of display digits present. If the decimal point is non zero then it will be sent in the appropriate place as “.” (46 Dec, 2E Hex). The tertiary display value, for instruments using a tertiary display value, is shown in the table below.

Model	Quad display value
PM5-C0	Temperature 2 value
PM5-RS	Not used
PM5-TR	Not used

#### 5. Transmit Instrument Details and Software Version: <STX>IA<CR>

e.g. ^BI!^M using a terminal program (address 1) Instructs unit to return the details and software version number of the instrument.

Format of returned data is:-

<ACK>IA<c> YYYY AIC XXXXX ZZZ.Z <CR>

Where:

<ACK>	is Acknowledge (6 Dec, 06 Hex)
I	is echo command received “I” (73 Dec, 49 Hex)
A	is the responding units address
<c>	is a copyright symbol
YYYY	is the year of production
AIC	is the manufacturer name
XXXX	is the input circuit identifier
ZZZ.Z	is the software version

#### 10. Invalid Command

If the command received from the host is not valid then the unit will return the following:-

<ACK>?A<CR>

Where:

<ACK>	is Acknowledge (6 Dec, 06 Hex)
?	is the character “?” (63 Dec, 3F Hex)
A	is the responding units address
<CR>	is a Carriage Return (13 Dec, 0D Hex)

If the address received from the host does not match the units address then the unit will not respond at all.

**Host Timing Requirements for RS485 Operation:**

RS485 operation requires the host to switch the RS485 transceiver to transmit before a command is sent. The instrument is capable of replying after 1 to 2 milliseconds. Therefore the host should switch the RS485 transceiver back to receive mode within 0.5 milliseconds after the last character of the command has been sent to ensure correct operation.

# 11 Ethernet plus RS232/RS485 plus datalogger

This chapter deals with the the Ethernet option. The Ethernet option board is fitted with inbuilt datalogging (8M byte minimum memory) and RS232 and RS485. Both RS232 and RS485 are fitted to the option board but only one of these can be used at a time. An optional form A relay is also available rated at 5A, 240VAC into a resistive load.

Windows compatible software (not Vista) and an instruction manual will be provided with this option. The setup of this option is carried out via this software and not through the instrument pushbuttons.

Option code	Options fitted to the board
-ETDL	Ethernet plus RS232/RS485
-ETDLR	Ethernet plus RS232/RS485 plus extra relay

## 11.1 Electrical Connections

All electrical connections are at the rear of the instrument. The plug in screw connectors used allow wire of up to 2.5mm<sup>2</sup>. Refer to “Electrical Installation” chapter in the main PM5 manual for general information on electrical connections.

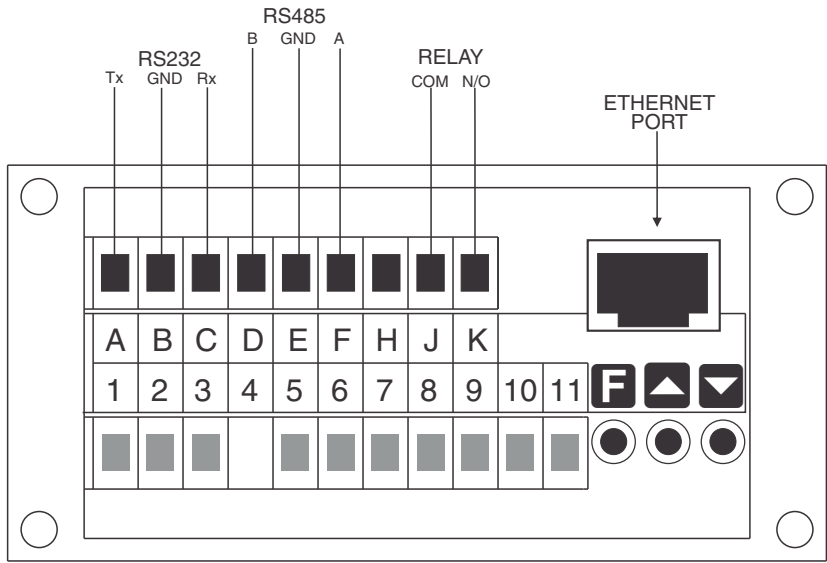



## 12 Analog PI control output

PI control functions will only be seen if PI control software is available for the instrument and if the optional isolated analog or dual isolated analog output is fitted.

The PI (proportional + integral) control output may be configured for proportional only (i.e. integral gain set to 0.000) or proportional + integral control. Using the control function settings described below the instrument will vary the control output signal in such a way that the process being monitored is kept as close as possible to the control setpoint. The control may be turned on or off via the function. When the function is set to **OFF** the output will act as a retransmission output rather than a control output and the PI control functions will not be seen. When set to **ON** the PI control functions will be seen but the standard retransmission functions (e.g. **LO** and **HIGH**) will not. The best PI control results are usually achieved by initially configuring as a proportional only controller and introducing the Integral control once stable results have been obtained from proportional only control.

### 12.1 Proportional control output

For proportional only control the output is found from:

$$\text{Proportional control output} = \text{Error} \times \text{Proportional gain} + \text{Offset}$$

Where the Error is defined by the function, the Proportional gain is set by the function and the Offset is set by the function.

### 12.2 Analog output 1 PI control on or off

Display: **P.C.T.I**  
Range: **NO** or **YES**  
Default Value: **NO**

Allows selection of retransmission (**NO**) or PI control analog output (**YES**). If set to **NO** then the analog output will operate as a retransmission output using the limits set at the **LO** and **HIGH** functions. If set to **YES** then the analog output will operate as a PI control output and the PI control functions will appear.

To set the selection go to the function, press **F** and when you see the decimal points flash use the **▲** or **▼** push buttons to select the required setting then press **F** to accept this selection.

### 12.3 Analog output 1 PI control setpoint

Display: **SEtP**  
Range: Any display value  
Default Value: **0**

Allows selection of the PI control setpoint.

The control setpoint is set to the value in displayed units required for control of the process. The controller will attempt to vary the control output to keep the process variable at the setpoint.

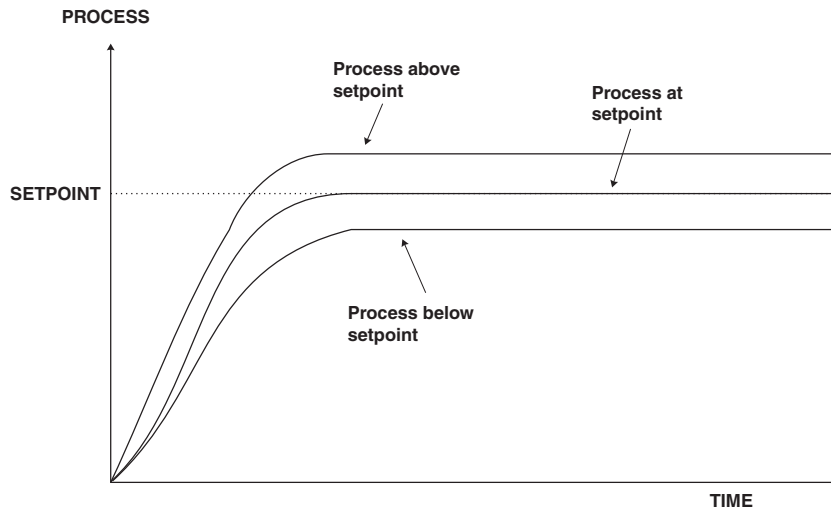

To set the selection go to the function, press **F** and when you see a digit of the value flash use the **▲** or **▼** push buttons to set the required value then press **F** to accept this selection.

## 12.4 Analog output 1 PI control span

Display: **SPAN**  
 Range: Any display value  
 Default Value: **1000**

Allows selection of the PI control span. The function of the control span is to define the limit to which the proportional control values will relate. The span value defines the range over which the input must change to cause a 100% change in the control output when the proportional gain is set to 1.000. This function affects the overall gain of the controller and is normally set to the process value limits that the controller requires for normal operation. For example if the control setpoint ( ) is **50.0** and the is **15** then an error of 15 from the setpoint will cause a 100% change in proportional control output.

For example, assuming that the control output is a 4-20mA signal, with at **50.0**, at **15.0**, at **1.000** and **C.P0** at **0.000** a display reading of **35.0** or lower ( - ) the control output will be at 100% i.e. 20mA. The control output will then gradually fall as the display value reaches the setpoint.

To set the value go to the function, press **F** and when you see a digit of the value flash use the **▲** or **▼** push buttons to set the required value then press **F** to accept this selection.

## 12.5 Analog output 1 PI control proportional gain

Display: **P.G**  
 Range: **-32.768** to **32.767**  
 Default Value: **1.000**

Allows selection of the PI control proportional gain.

The proportional gain is the ratio between the change in measured input and change in control output. Too much proportional gain will result in instability.

**Example 1** - if the proportional gain is set to **1.000** and the measured input changes by 100% of the span set in then the output will change by 100%.

**Example 2** - if the proportional gain is set to **2.000** and the measured input changes by 50% of the range set in then the output will change by 100%.

**Example 3** - if the proportional gain is set to **2.000** and the measured input changes by 25% of the range set in then the output will change by 50%.

Setting a negative proportional gain will reverse the control output.

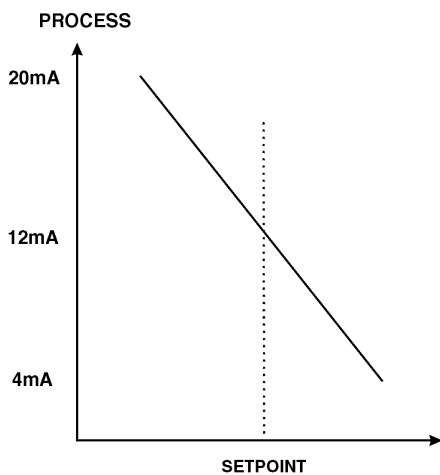
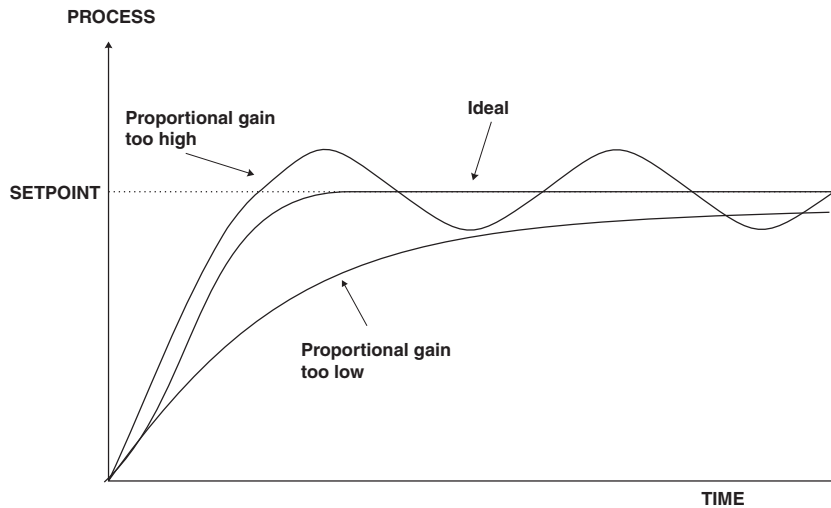

Positive P.G value e.g. **1.000**

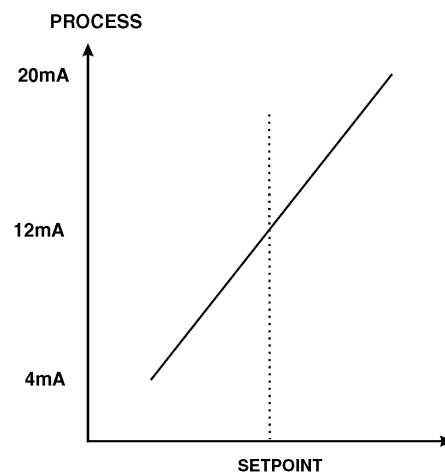

Negative P.G value e.g. **-1.000**

To set the value go to the function, press **F** and when you see a digit of the value flash use the **▲** or **▼** push buttons to set the required value then press **F** to accept this selection.

## 12.6 Analog output 1 PI control bias

Display: **b, 95**  
 Range: **0.0 to 100.0**  
 Default Value: **50.0**

Allows selection of the PI control bias. The bias is initially used to set the output value when operating the instrument as a proportional only controller. The bias determines what % of the proportional control output will be given when the process value reaches the setpoint value. If set to **0.000** then there will be zero output (e.g. 4mA for a 4-20mA output) when the process value reaches the setpoint value. If set to **0.500** then there will be a 50% output (e.g. 12mA for a 4-20mA output) when the process reaches the setpoint value. If set to **1.000** then there

will be a 100% output (e.g. 20mA for a 4-20mA output) when the process reaches the setpoint value. If using proportional only control then when stable control is established there may be a difference between the process and the setpoint values. By altering the bias value the difference may be minimised.

To set the value go to the function, press **F** and when you see a digit of the value flash use the **▲** or **▼** push buttons to set the required value then press **F** to accept this selection.

This table shows the effect of the output current of changing proportional gain and offset with the following settings: = <b>2.00</b> , = <b>0.000</b>			
			Effect on analog output (4-20mA used in this example)
<b>7.00</b>	<b>1.000</b>	<b>0.000</b>	Reading of 5.00 or below - 20mA output Reading of 5.00 to 7.00 - mA output decreasing as reading approaches 9.00 Reading 7.00 or above - 4mA output
<b>7.00</b>	<b>1.000</b>	<b>1.000</b>	Reading of 7.00 or below - 20mA output Reading of 7.00 to 9.00 - mA output decreasing as reading approaches 9.00 Reading 9.00 or above - 4mA output
<b>7.00</b>	<b>1.000</b>	<b>0.500</b>	Reading of 6.00 or below - 20mA output Reading of 6.00 to 8.00 - mA output decreasing as reading approaches 8.00 with 12mA output at 7.00 Reading 8.00 or above - 4mA output
<b>7.00</b>	<b>0.500</b>	<b>0.500</b>	Reading 5.00 or below - 20mA output Reading 5.00 to 9.00 - mA output decreasing as reading approaches 9.00 with 12mA output at 7.00 Reading 9.00 or above - 4mA output
<b>7.00</b>	<b>- 1.000</b>	<b>0.500</b>	Reading of 6.00 or below - 4mA output Reading of 6.00 to 8.00 - mA output increasing as reading approaches 8.00 with 12mA output at 7.00 Reading 8.00 or above - 20mA output

## 12.7 Integral control output

The integral control output can be found from:

$$\text{Integral control output} = \frac{\text{Error} \times I.G \times \text{time}(secs)}{60} + \text{previous integral control output}$$

Where *I.G* is the integral gain is set by the function.

## 12.8 Analog output 1 PI control integral gain

Display: **1.9**  
Range: **-32.768 to 32.767**  
Default Value: **0.000**

Allows selection of the PI control integral gain. The integral control action will attempt to correct any offset which the proportional control action is unable to correct (e.g. errors due to a changing load). When the integral gain is correctly adjusted the control output is ramped up or down to maintain control by keeping the process variable at the same value as the control setpoint. An integral gain which is too large will cause a rapid response to any error but can also lead to overshooting and oscillation. An integral gain which is too small will slow the time taken to reach the setpoint. The optimum value chosen will depend on the lag time of the process and other control settings. Start with a low figure and increase until a satisfactory response time is reached.

The integral gain figure has units of gain/minute. Setting a negative integral gain will reverse the integral control action. If introduction of an integral gain figure causes the error to increase i.e. the process value is moving further away from the setpoint then check the sign of the integral gain e.g. if it is negative change it to a positive value.

Note that the sign of the integral gain value should be the same as the proportional gain value i.e. they should either both be positive or both be negative.

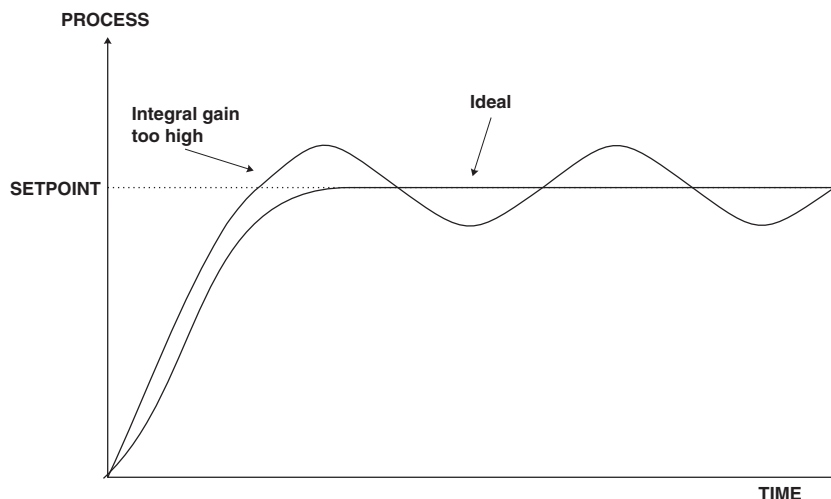

To set the value go to the function, press **F** and when you see a digit of the value flash use the **▲** or **▼** push buttons to set the required value then press **F** to accept this selection.

## 12.9 Analog output 1 PI control integral high limit

Display: **1.4**  
Range: **0.0 to 100.0**  
Default Value: **1.000**

Allows selection of the PI control integral high limit.

The high limit sets the maximum control output for the integral term i.e. puts a high level limit to the integral control current or voltage output. The limit is used to reduce available output swing and hence limit the effect of integral control output build up which can cause overshoot and instability in the system. If the process value is not close to the setpoint value then the integral

control will see a large error. Since integral control output increases with time, the longer an error is seen the more the integral control output will build up. Unless the output is limited then once the process reaches the setpoint the integral control output can be very large (e.g. 100%) causing the process value to overshoot the control setpoint. A setting which is too high will result in allowing the integral control output to cause overshooting. A setting which is too low will result in the integral control output being limited to an extent which means that the setpoint cannot be reached. Start with a low figure e.g. 10.0 and increase the value until a satisfactory response is reached. Maximum setting is 100.0 (100%). Having separate high and low limits is particularly useful if the process response is very one directional. For example in temperature control a heater may be used to give a fast response in heating a tank of liquid when the temperature falls below the setpoint. The heat of the liquid rises quickly but any overshoot will mean that the temperature is too high. The heater will be switched off but the tank of liquid will take a long time to cool to the setpoint level.

To set the value go to the function, press **F** and when you see a digit of the value flash use the **▲** or **▼** push buttons to set the required value then press **F** to accept this selection.

## 12.10 Analog output 1 PI control integral low limit

Display: **1.L**  
Range: **0.0 to 100.0**  
Default Value: **1.000**

Allows selection of the PI control integral low limit.

This function sets the minimum control output for the integral term value and works in the same manner as described above except that the setting controls the low swing.

To set the value go to the function, press **F** and when you see a digit of the value flash use the **▲** or **▼** push buttons to set the required value then press **F** to accept this selection.

## 12.11 Setting up the PI analog controller

1. Set the function to **YES**.
2. Set the control setpoint to the required setting.
3. Set the proportional control span as required.
4. Set the proportional gain to an arbitrary value e.g. 1.000.
5. Set the bias to 0.0 (0%).
6. Set the integral gain to 0.000 (i.e. off).
7. Set the integral high and low limits to an arbitrary value e.g. 20.00.

Initialise the control system and monitor the control results. If the original settings causes process oscillations then gradually decrease the proportional gain until the oscillations decrease to an acceptable steady cycle. If the original settings do not cause process oscillations then gradually increase the proportional gain until a steady process cycling is observed. Once the steady state is achieved note the difference between the display value and the control setpoint value. Gradually

increase or decrease the proportional offset value until the displayed value matches the control setpoint value.

If process load changes occur then the proportional offset value may no longer be valid for offset free control. By introducing the integral action, setpoint offset caused by the process load changes will be minimised. Gradually increase the integral gain until the process begins to oscillate. Then reduce the integral gain slightly to regain the control with minimum oscillation. Alter the high and low integral limits to give the best regulation with minimum oscillation. Create a step change to the process conditions and observe the control results. It may be necessary to fine tune the settings to obtain optimum results. The table below summarises the effect of the main function settings.

Setup functions	Symptom	Solution
Proportional gain	Slow response	Increase proportional gain
	High overshoot or oscillation	Decrease proportional gain
Bias	Process continually either above or below setpoint	Increase or decrease bias to compensate
Integral gain	Slow response	Increase integral gain
	Instability or oscillation	Decrease integral gain